

C50D-YL10 - S800 - M2 - M100W - B

型號 Model 孔型與導程 Hole type and Lead 行程 Stroke 馬達方向 Motor direction 馬達廠牌及出力 Motor brand and output 煞車 Brake

Y 底部牙孔
Thread hole

馬達方向 Motor direction

- M2 馬達外置 Motor outside position
- M3 馬達外置右側 Motor outside, rightward position
- M4 馬達外置左側 Motor outside, leftward position
- M5 馬達外置上方 Motor outside, upper position
- M6 馬達外置下方 Motor outside, lower position

馬達廠牌及出力 Motor brand and output

- H 上銀 Hiwin
- X 西門子 Siemens
- M 三菱 Mitsubishi
- Y 安川 Yaskawa
- P 松下 Panasonic
- F 富士 Fuji
- T 台達 Delta

C50D規格表(C50D Specification):

馬達出力 AC Servo motor output(W)	100W	
重覆定位精度 Repeatability(mm)	±0.01	
滾珠螺桿外徑 B.S(Ø)	12	12
滾珠螺桿導程 Lead(mm)	5	10
最快速度 Maximun speed(mm/sec)	250	500
最大載重 Maximun payload(kg)	水平使用 (H)	5.5
	垂直使用 (V)	1.2
額定推力 Rated thrust(N)	70	35
行程 Stroke(mm)	100~800 50 間隔 (interval)	

線性滑軌24x8.5-1支

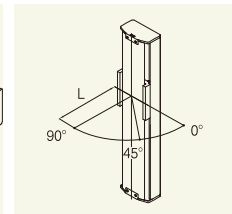
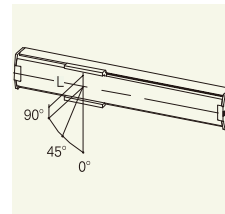
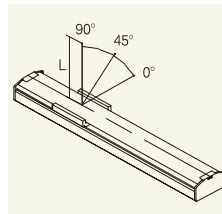

水平安裝應用 (單位:mm)
Horizontal use

導程 Payload	0°	45°	90°
Lead 10	2kg 385	220	800
	4kg 170	90	330
	5.5kg 75	40	120
Lead 05	3kg 235	140	730
	6kg 125	60	460
	9kg 35	10	295

牆面安裝應用 (單位:mm)
Wall installation use

導程 Payload	0°	45°	90°
Lead 10	2kg 700	100	310
	4kg 385	50	110
	5.5kg 250	25	85
Lead 05	3kg 800	90	235
	6kg 520	20	130
	9kg 370	0	50

垂直安裝應用 (單位:mm)
During vertical use

導程 Payload	0°	45°	90°
Lead 10	1.2kg 220	70	220
Lead 05	2.5kg 105	25	105

*滑塊表面中心到搬送物重心的距離 (僅供參考)
Distance center of slider top to center of gravity of object being transported (For reference only)

靜態容許負載慣量
Stidic Loading Moment

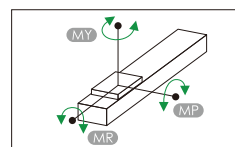

(單位:N.m) (Unit:N.m)
水平使用時 Static Loading Moment

MY	16
MP	20
MR	19

"此款型號不建議當多軸負載軸"
This model suggest not be used as load axis of multi axes.

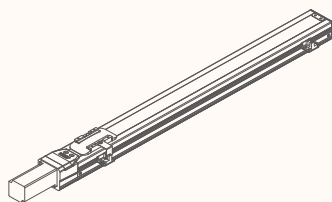

M2

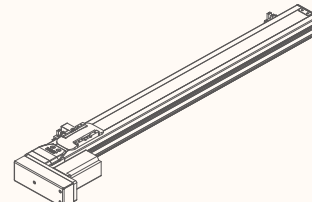

M3

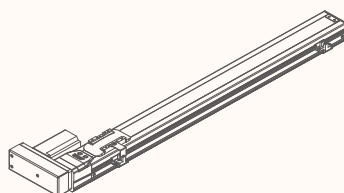

M4

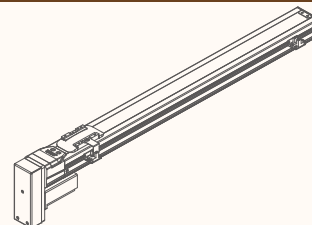

M6

M2

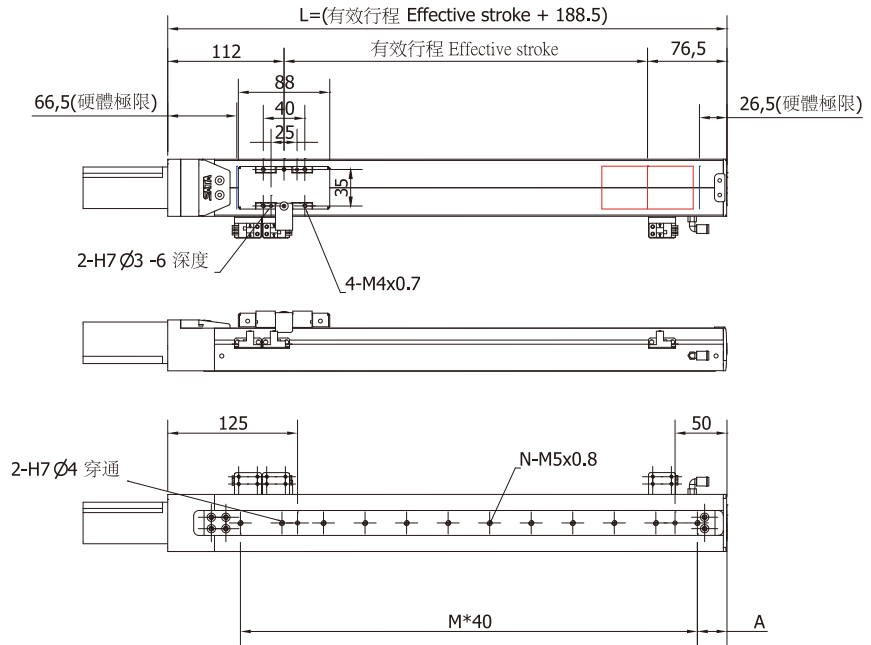

行程	100	150	200	250	300	350	400	450	500	550	600	650	700	750	800
L	288.5	338.5	388.5	438.5	488.5	538.5	588.5	638.5	688.5	738.5	788.5	838.5	888.5	938.5	988.5
A	38.5	28.5	38.5	28.5	38.5	28.5	38.5	28.5	38.5	28.5	38.5	28.5	38.5	28.5	38.5
M	4	6	7	8	9	11	12	13	14	16	17	18	19	21	22
N	5	7	8	9	10	12	13	14	15	17	18	19	20	22	23
重量(kg)	2.6	2.7	2.8	2.9	3.0	3.1	3.2	3.3	3.4	3.5	3.6	3.7	3.8	3.9	4.0

※本公司享有變更規格之權益，恕不另行通知 ※Drawings and specifications are subject to change without prior notice.

M3

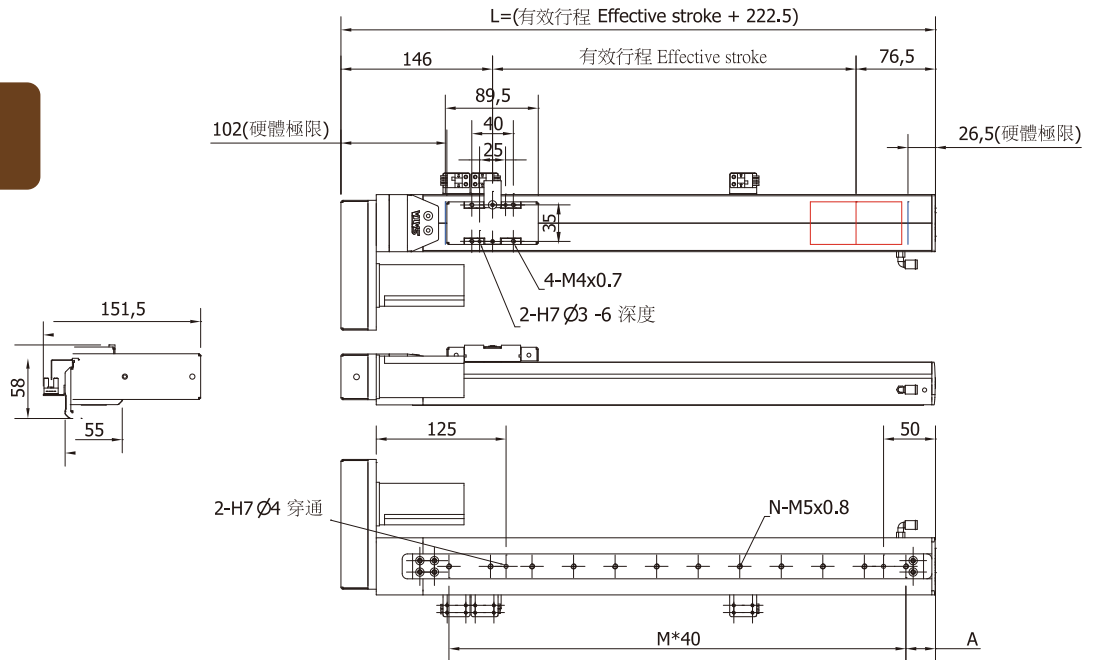

行程	100	150	200	250	300	350	400	450	500	550	600	650	700	750	800
L	332.5	372.5	422.5	472.5	522.5	572.5	622.5	672.5	722.5	772.5	822.5	872.5	922.5	972.5	1022.5
A	38.5	28.5	38.5	28.5	38.5	28.5	38.5	28.5	38.5	28.5	38.5	28.5	38.5	28.5	38.5
M	4	6	7	8	9	11	12	13	14	16	17	18	19	21	22
N	5	7	8	9	10	12	13	14	15	17	18	19	20	22	23
重量(kg)	3.0	3.1	3.2	3.3	3.4	3.5	3.6	3.7	3.8	3.9	4.0	4.1	4.2	4.3	4.4

※本公司享有變更規格之權益，恕不另行通知 ※Drawings and specifications are subject to change without prior notice.

M4

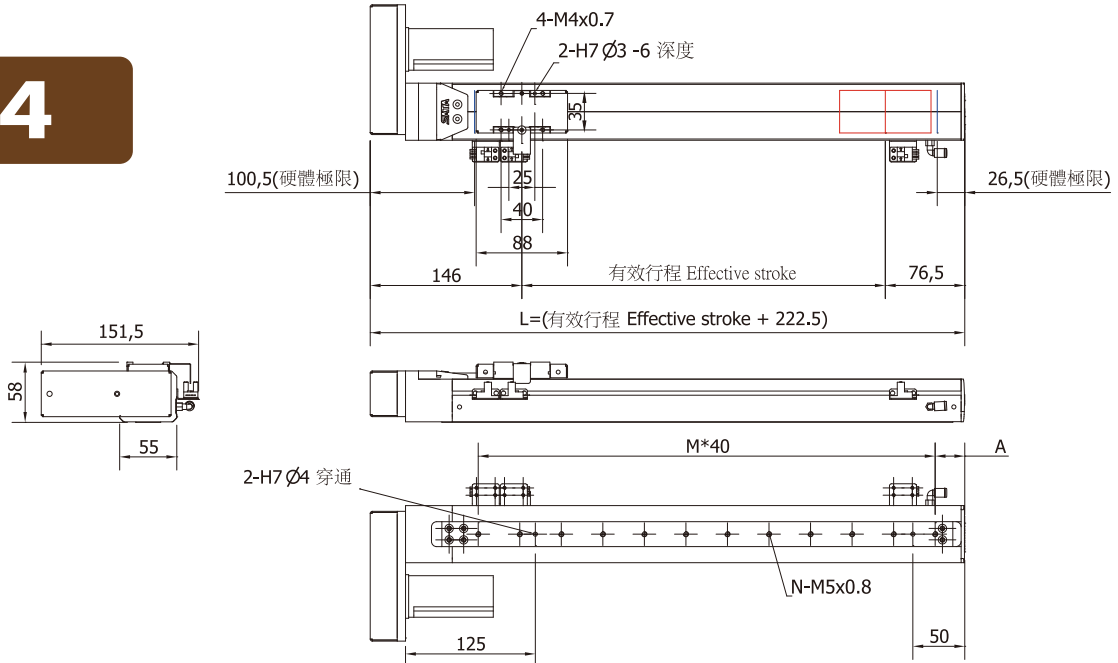

行程	100	150	200	250	300	350	400	450	500	550	600	650	700	750	800
L	332.5	372.5	422.5	472.5	522.5	572.5	622.5	672.5	722.5	772.5	822.5	872.5	922.5	972.5	1022.5
A	38.5	28.5	38.5	28.5	38.5	28.5	38.5	28.5	38.5	28.5	38.5	28.5	38.5	28.5	38.5
M	4	6	7	8	9	11	12	13	14	16	17	18	19	21	22
N	5	7	8	9	10	12	13	14	15	17	18	19	20	22	23
重量(kg)	3.0	3.1	3.2	3.3	3.4	3.5	3.6	3.7	3.8	3.9	4.0	4.1	4.2	4.3	4.4

※本公司享有變更規格之權益，恕不另行通知 ※Drawings and specifications are subject to change without prior notice.

M6

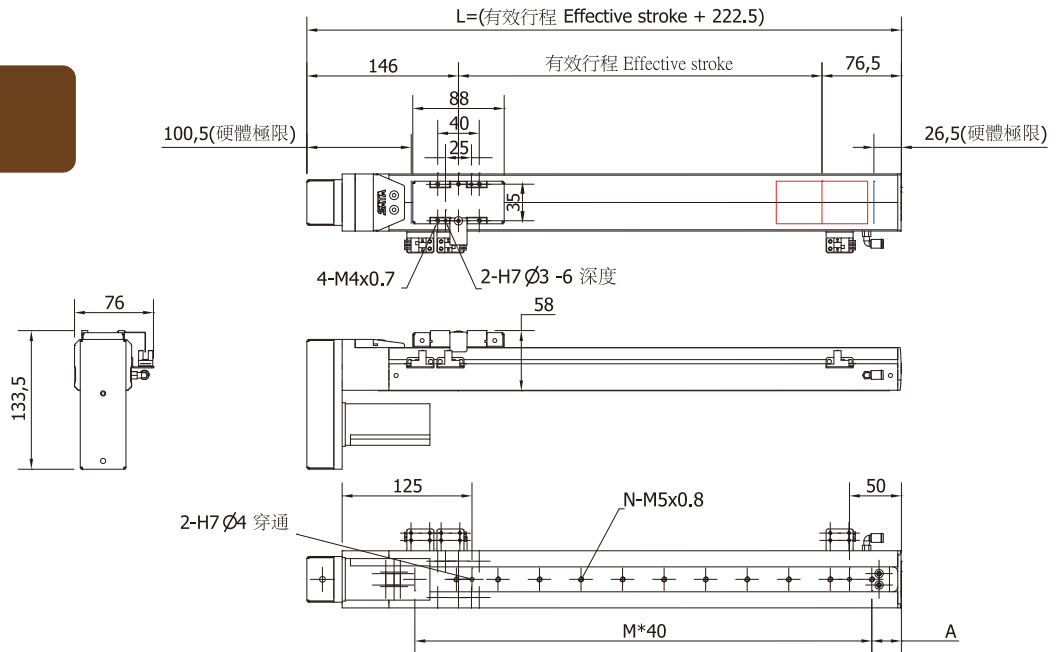

行程	100	150	200	250	300	350	400	450	500	550	600	650	700	750	800
L	332.5	372.5	422.5	472.5	522.5	572.5	622.5	672.5	722.5	772.5	822.5	872.5	922.5	972.5	1022.5
A	38.5	28.5	38.5	28.5	38.5	28.5	38.5	28.5	38.5	28.5	38.5	28.5	38.5	28.5	38.5
M	4	6	7	8	9	11	12	13	14	16	17	18	19	21	22
N	5	7	8	9	10	12	13	14	15	17	18	19	20	22	23
重量(kg)	3.0	3.1	3.2	3.3	3.4	3.5	3.6	3.7	3.8	3.9	4.0	4.1	4.2	4.3	4.4

※本公司享有變更規格之權益，恕不另行通知 ※Drawings and specifications are subject to change without prior notice.

C60D - YL10 - S800 - M2 - M 100W - B

型號 Model	孔型與導程 Hole type and Lead	行程 Stroke	馬達方向 Motor direction	馬達廠牌及出力 Motor brand and output	煞車 Brake
	Y 底部牙孔 Thread hole			馬達廠牌及出力 Motor brand and output	
		馬達方向 Motor direction			
		M2 馬達外置 Motor outside position		H 上銀 Hiwin	
		M3 馬達外置右側 Motor outside, rightward position		X 西門子 Siemens	
		M4 馬達外置左側 Motor outside, leftward position		M 三菱 Mitsubishi	
		M5 馬達外置上方 Motor outside, upper position		Y 安川 Yaskawa	
		M6 馬達外置下方 Motor outside, lower position		P 松下 Panasonic	
				F 富士 Fuji	
				T 台達 Delta	

C60D規格表(C60D Specification):

馬達出力 AC Servo motor output(W)	100W		
重覆定位精度 Repeatability(mm)	±0.01		
滾珠螺桿外徑 B.S(Ø)	12	12	
滾珠螺桿導程 Lead(mm)	5	10	
最快速度 Maximun speed(mm/sec)	250	500	
最大載重 Maximun payload(kg)	水平使用 (H)	30	15
	垂直使用 (V)	9	5
額定推力 Rated thrust(N)	250	130	
行程 Stroke(mm)	100~800 50 間隔(interval)		

線性滑軌 42x9.5-1 支

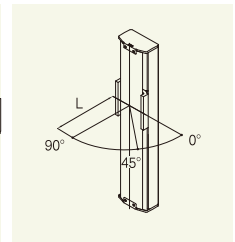
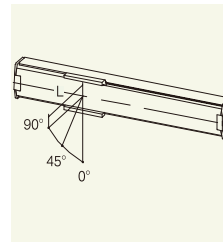
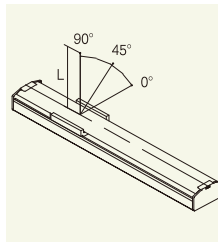

水平安裝應用(單位:mm) Horizontal use				
導程 Payload	0°	45°	90°	
Lead 10	4kg	306	392	585
	9kg	111	163	230
	15kg	20	48	124
Lead 05	5kg	211	370	650
	10kg	78	156	339
	30kg	21	85	148

牆面安裝應用(單位:mm) Wall installation use				
導程 Payload	0°	45°	90°	
Lead 10	4kg	500	390	287
	9kg	198	88	65
	15kg	61	29	12
Lead 05	5kg	509	374	172
	10kg	223	96	46
	30kg	0	0	0

垂直安裝應用(單位:mm) During vertical use				
導程 Payload	0°	45°	90°	
Lead 10	1kg	340	226	340
	3kg	144	79	144
	5kg	31	0	31
Lead 05	4kg	77	48	77
	7kg	31	6	31
	9kg	0	0	0

*滑塊表面中心到搬送物重心的距離(僅供參考)
Distance center of slider top to center of gravity of object being transported (For reference only)

靜態容許負載慣量
Staic Loading Moment

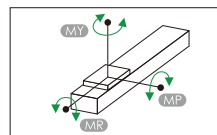

(單位:N.m) (Unit:N.m)
水平使用時 Static Loading Moment

MY	70
MP	80
MR	75

"此款型號不建議當多軸負載軸"
This model suggest not be used as load axis of multi axes.



M2

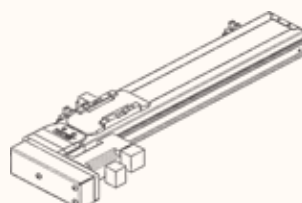

M3

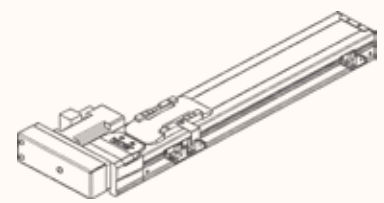

M4



M5

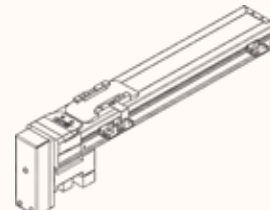

M6

M2

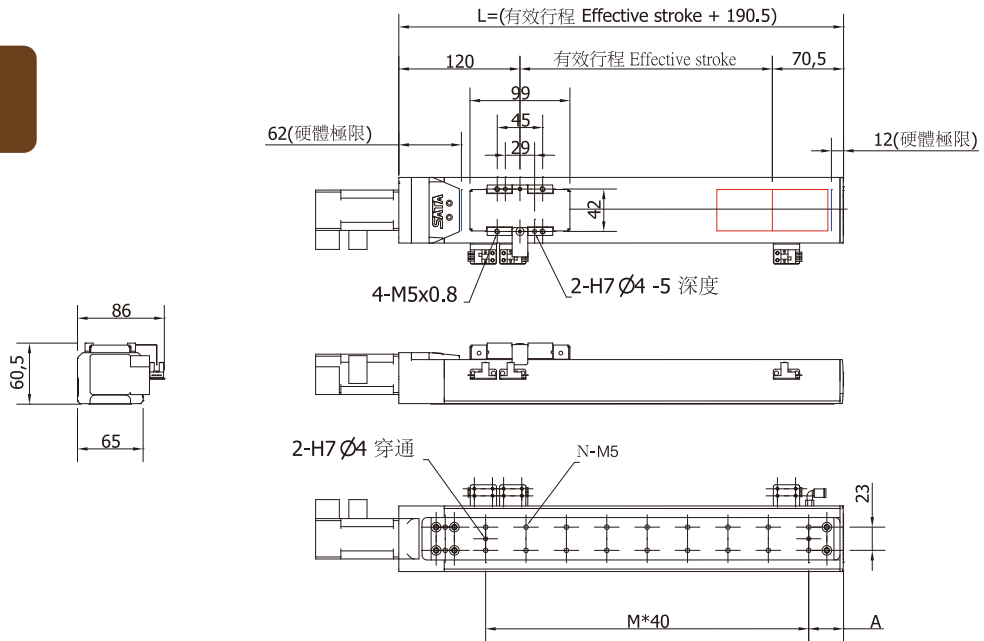

行程	100	150	200	250	300	350	400	450	500	550	600	650	700	750	800
L	290.5	340.5	390.5	440.5	490.5	540.5	590.5	640.5	690.5	740.5	790.5	840.5	890.5	940.5	990.5
A	44.5	34.5	44.5	34.5	44.5	34.5	44.5	34.5	44.5	34.5	44.5	34.5	44.5	34.5	44.5
M	4	6	7	8	9	11	12	13	14	16	17	18	19	21	22
N	10	14	16	18	20	24	26	28	30	34	36	38	40	44	46
重量(kg)	2.9	3.1	3.3	3.5	3.7	3.9	4.1	4.3	4.5	4.7	4.9	5.1	5.3	5.5	5.7

※本公司享有變更規格之權益，恕不另行通知 ※Drawings and specifications are subject to change without prior notice.

M3

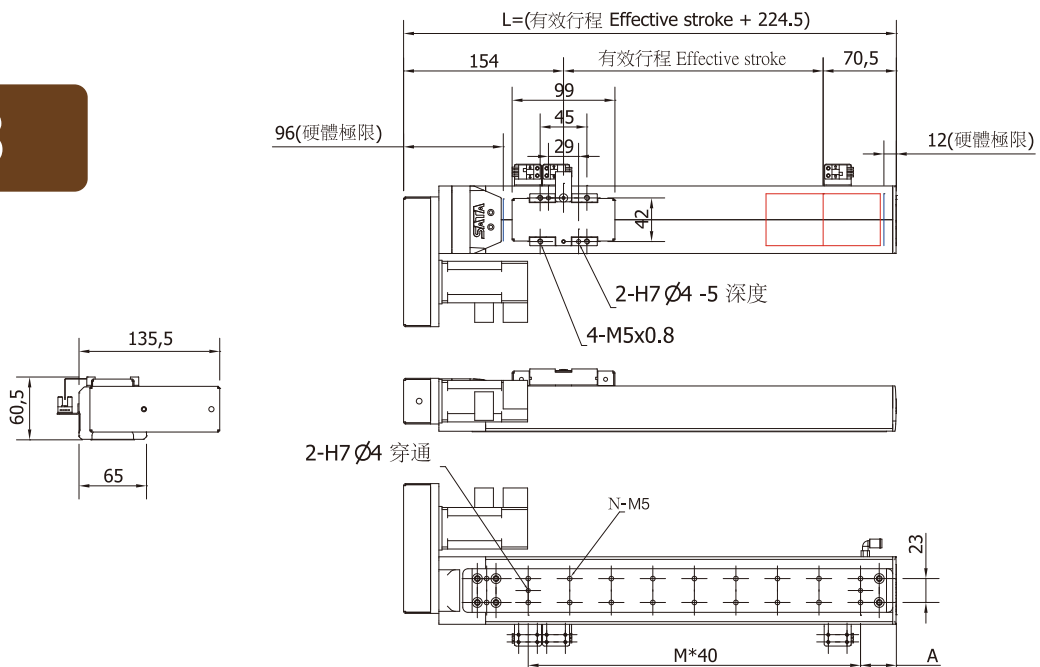

行程	100	150	200	250	300	350	400	450	500	550	600	650	700	750	800
L	324.5	374.5	424.5	474.5	524.5	574.5	624.5	674.5	724.5	774.5	824.5	874.5	924.5	974.5	1024.5
A	44.5	34.5	44.5	34.5	44.5	34.5	44.5	34.5	44.5	34.5	44.5	34.5	44.5	34.5	44.5
M	4	6	7	8	9	11	12	13	14	16	17	18	19	21	22
N	10	14	16	18	20	24	26	28	30	34	36	38	40	44	46
重量(kg)	3.3	3.5	3.7	3.9	4.1	4.3	4.5	4.7	4.9	5.1	5.3	5.5	5.7	5.9	6.1

※本公司享有變更規格之權益，恕不另行通知 ※Drawings and specifications are subject to change without prior notice.

M4

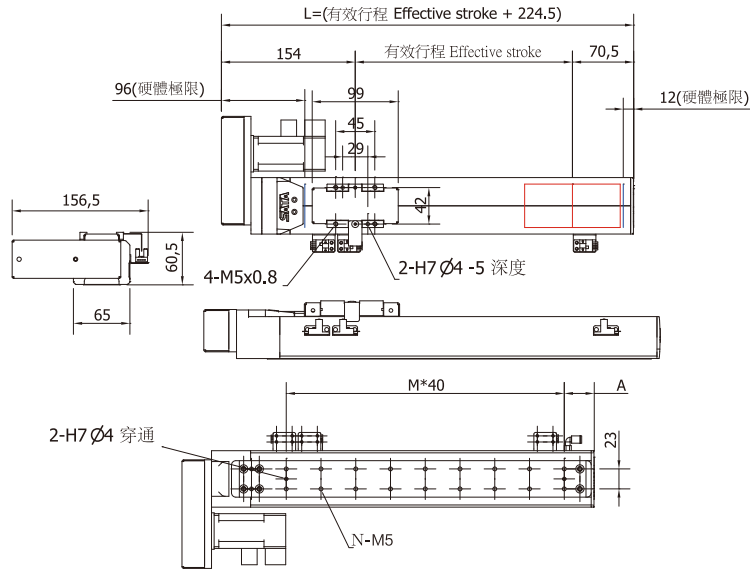

行程	100	150	200	250	300	350	400	450	500	550	600	650	700	750	800
L	324.5	374.5	424.5	474.5	524.5	574.5	624.5	674.5	724.5	774.5	824.5	874.5	924.5	974.5	1024.5
A	44.5	34.5	44.5	34.5	44.5	34.5	44.5	34.5	44.5	34.5	44.5	34.5	44.5	34.5	44.5
M	4	6	7	8	9	11	12	13	14	16	17	18	19	21	22
N	10	14	16	18	20	24	26	28	30	34	36	38	40	44	46
重量(kg)	3.3	3.5	3.7	3.9	4.1	4.3	4.5	4.7	4.9	5.1	5.3	5.5	5.7	5.9	6.1

※本公司享有變更規格之權益，恕不另行通知 ※Drawings and specifications are subject to change without prior notice.

M6

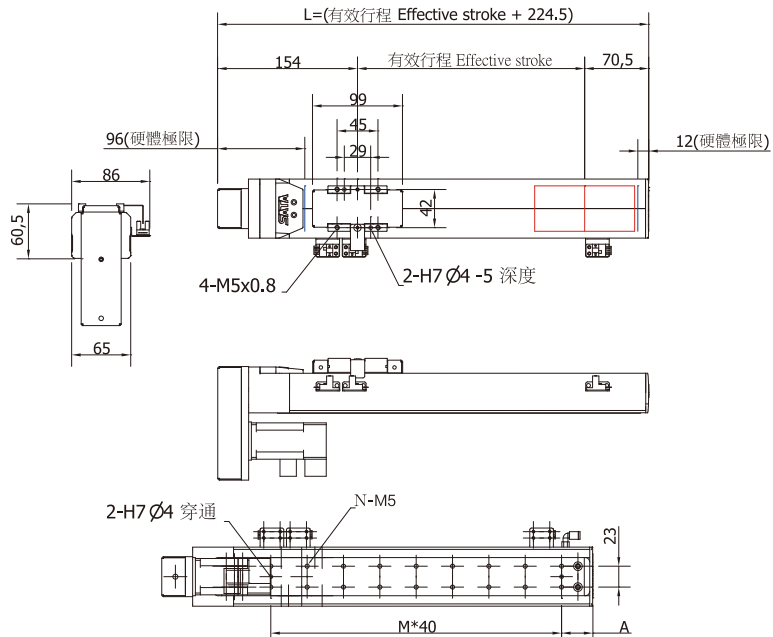

行程	100	150	200	250	300	350	400	450	500	550	600	650	700	750	800
L	324.5	374.5	424.5	474.5	524.5	574.5	624.5	674.5	724.5	774.5	824.5	874.5	924.5	974.5	1024.5
A	44.5	34.5	44.5	34.5	44.5	34.5	44.5	34.5	44.5	34.5	44.5	34.5	44.5	34.5	44.5
M	4	6	7	8	9	11	12	13	14	16	17	18	19	21	22
N	10	14	16	18	20	24	26	28	30	34	36	38	40	44	46
重量(kg)	3.3	3.5	3.7	3.9	4.1	4.3	4.5	4.7	4.9	5.1	5.3	5.5	5.7	5.9	6.1

※本公司享有變更規格之權益，恕不另行通知 ※Drawings and specifications are subject to change without prior notice.

C80D -YL10 - S800 - M2 - M 100W - B

型號 Model 孔型與導程 Hole type and Lead 行程 Stroke 馬達方向 Motor direction 馬達廠牌及出力 Motor brand and output 煞車 Brake

Y 底部牙孔
Thread hole

馬達方向 Motor direction

- M1 馬達內置 Motor inside position
- M2 馬達外置 Motor outside position
- M3 馬達外置右側 Motor outside, rightward position
- M4 馬達外置左側 Motor outside, leftward position
- M5 馬達外置上方 Motor outside, upper position
- M6 馬達外置下方 Motor outside, lower position

馬達廠牌及出力 Motor brand and output

- H 上銀 Hiwin
- X 西門子 Siemens
- M 三菱 Mitsubishi
- Y 安川 Yaskawa
- P 松下 Panasonic
- F 富士 Fuji
- T 台達 Delta

C80D規格表(C80D Specification):

馬達出力 AC Servo motor output(W)	100W				
重覆定位精度 Repeatability(mm)	±0.01				
滾珠螺桿外徑 B.S.(Ø)	16	16	16	16	
滾珠螺桿導程 Lead(mm)	5	10	16	20	
最快速度 Maximun speed(mm/sec)	250	500	800	1000	
最大載重 Maximun payload(kg)	水平使用 (H)	35	25	15	10
	垂直使用 (V)	13	9	5	4
額定推力 Rated thrust(N)	300	150	85	75	
行程 Stroke(mm)	100~1050 50 間隔 (interval)				

線性滑軌15x12.5-1支

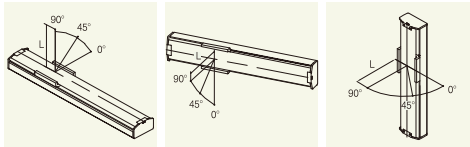

水平安裝應用(單位:mm) Horizontal use				牆面安裝應用(單位:mm) Wall installation use				垂直安裝應用(單位:mm) During vertical use							
導程 Lead	荷重 Payload	0°	45°	90°	導程 Lead	荷重 Payload	0°	45°	90°	導程 Lead	荷重 Payload	0°	45°	90°	
4k	170	235	598	4k	266	77	75	1k	273	193	273	1k	273	193	273
7k	77	121	321	7k	139	33	22	2k	127	80	127	2k	127	80	127
10k	35	39	176	10k	25	0	0	3k	31	0	31	3k	31	0	31
4k	212	300	766	4k	380	128	106	1k	455	321	455	1k	455	321	455
9k	109	151	401	9k	198	50	31	2k	212	133	212	2k	212	133	212
15k	43	48	220	13k	35	0	0	4k	52	10	52	4k	52	10	52
14k	70	112	375	10k	502	247	120	3k	366	207	366	3k	366	207	366
21k	35	42	217	16k	189	115	71	6k	141	42	141	6k	141	42	141
25k	0	0	98	20k	52	7	0	9k	38	0	58	9k	38	0	58
25k	0	0	226	15k	313	160	94	5k	285	167	285	5k	285	167	285
30k	0	0	103	21k	154	33	0	10k	129	25	166	10k	129	25	166
35k	0	0	21	25k	15	0	0	13k	10	0	42	13k	10	0	42

*滑塊表面中心到搬送物重心的距離(僅供參考)
Distance center of slider top to center of gravity of object being transported (For reference only)

靜態容許負載慣量
Stidc Loading Moment

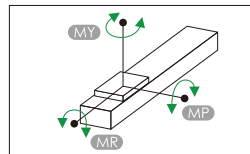

(單位:N.m) (Unit:N.m)
水平使用時 Static Loading Moment

MY	95
MP	95
MR	100

"此款型號不建議當多軸負載軸"
This model suggest not be used as load axis of multi axes.

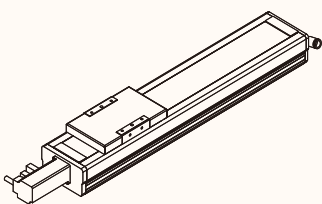

M2

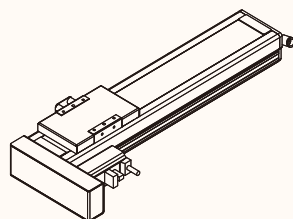

M3

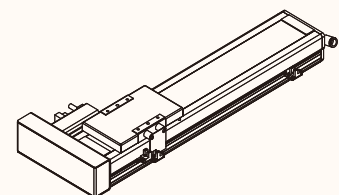

M4

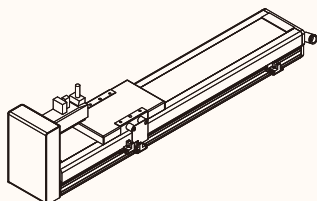

M5

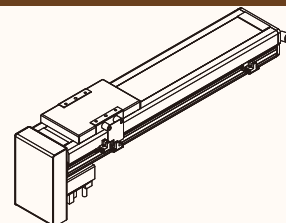

M6

M2

螺桿傳動—無塵環境 Ball-Screw Series-Clean Room

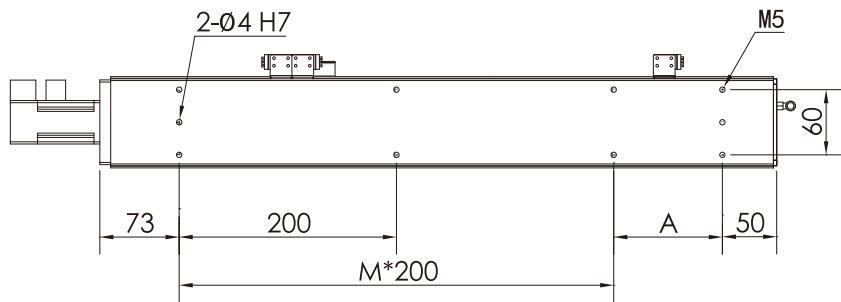
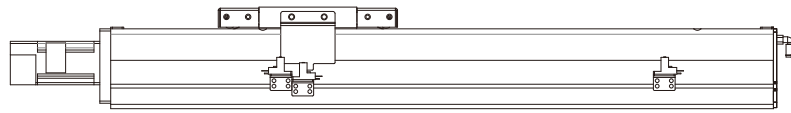
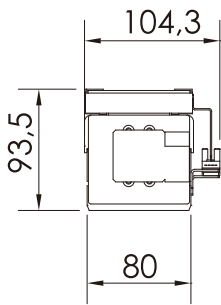
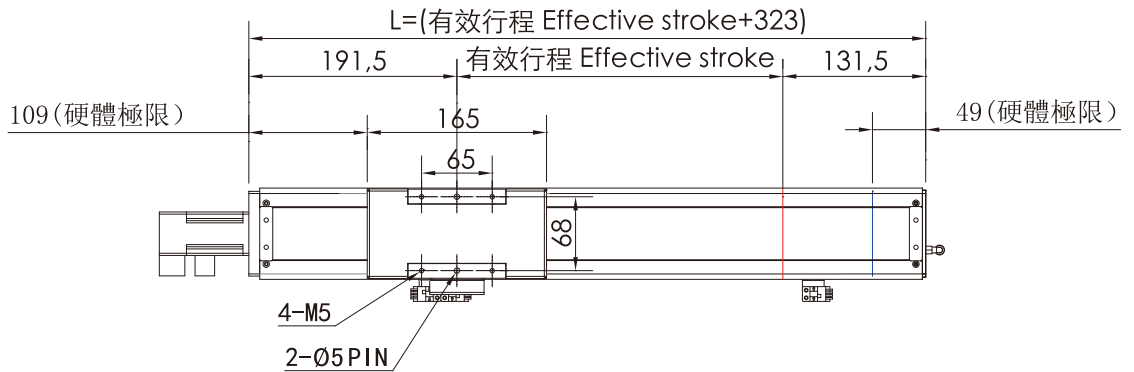

行程	100	150	200	250	300	350	400	450	500	550	600	650	700	750	800	850	900	950	1000	1050
L	423	473	523	573	623	673	723	773	823	873	923	973	1023	1073	1123	1173	1223	1273	1323	1373
A	100	150	200	50	100	150	200	50	100	150	200	50	100	150	200	50	100	150	200	50
M	1	1	1	2	2	2	2	3	3	3	3	4	4	4	4	5	5	5	5	6
N	6	6	6	8	8	8	8	10	10	10	10	12	12	12	12	14	14	14	14	15
重量(kg)	4.3	4.8	5.3	5.8	6.3	6.8	7.3	7.8	8.3	8.7	9.3	9.8	10.3	10.8	11.3	11.8	12.3	12.8	13.3	13.8

※本公司享有變更規格之權益，恕不另行通知 ※Drawings and specifications are subject to change without prior notice.

M3

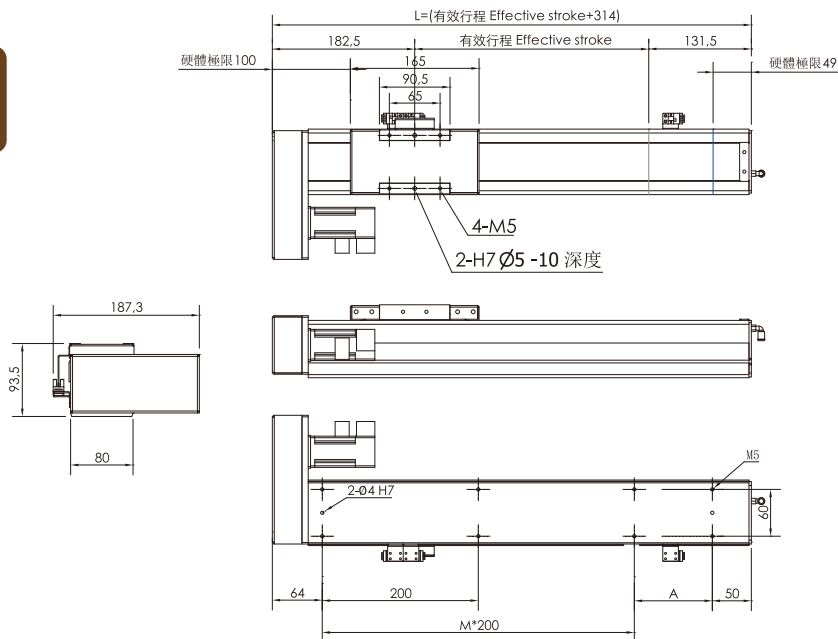

行程	100	150	200	250	300	350	400	450	500	550	600	650	700	750	800	850	900	950	1000	1050
L	414	464	514	564	614	664	714	764	814	864	914	964	1014	1064	1114	1164	1214	1264	1314	1364
A	100	150	200	50	100	150	200	50	100	150	200	50	100	150	200	50	100	150	200	50
M	1	1	1	2	2	2	2	3	3	3	3	4	4	4	4	5	5	5	5	6
N	6	6	6	8	8	8	8	10	10	10	10	12	12	12	12	14	14	14	14	15
重量(kg)	5.1	5.4	5.7	6.0	6.3	6.6	6.9	7.2	7.5	7.8	8.1	8.4	8.7	9.0	9.3	9.6	9.9	10.2	10.5	10.8

※本公司享有變更規格之權益，恕不另行通知 ※Drawings and specifications are subject to change without prior notice.

M4

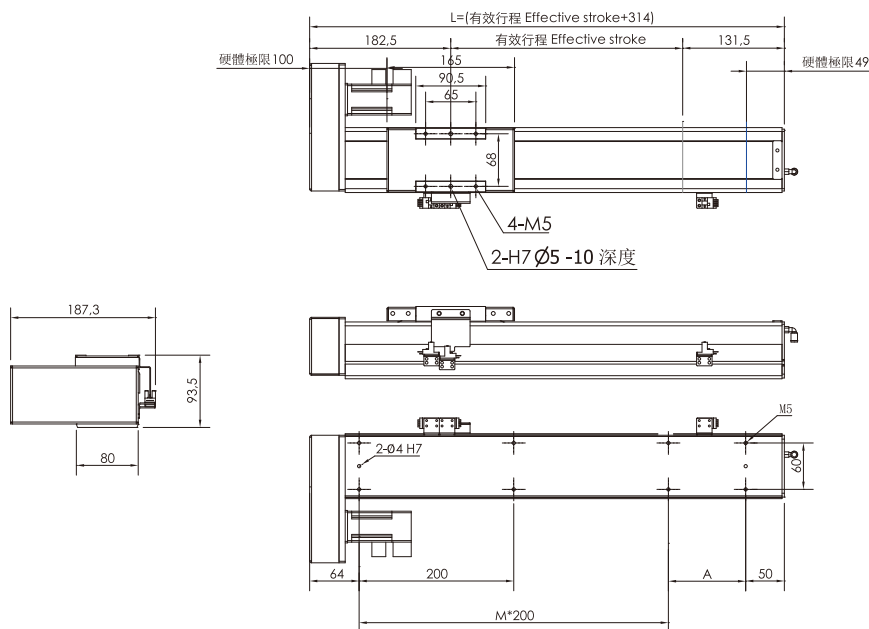

行程	100	150	200	250	300	350	400	450	500	550	600	650	700	750	800	850	900	950	1000	1050
L	414	464	514	564	614	664	714	764	814	864	914	964	1014	1064	1114	1164	1214	1264	1314	1364
A	100	150	200	50	100	150	200	50	100	150	200	50	100	150	200	50	100	150	200	50
M	1	1	1	2	2	2	2	3	3	3	3	4	4	4	4	5	5	5	5	6
N	6	6	6	8	8	8	8	10	10	10	10	12	12	12	12	14	14	14	14	15
重量(kg)	5.1	5.4	5.7	6.0	6.3	6.6	6.9	7.2	7.5	7.8	8.1	8.4	8.7	9.0	9.3	9.6	9.9	10.2	10.5	10.8

※本公司享有變更規格之權益，恕不另行通知 ※Drawings and specifications are subject to change without prior notice.

M5

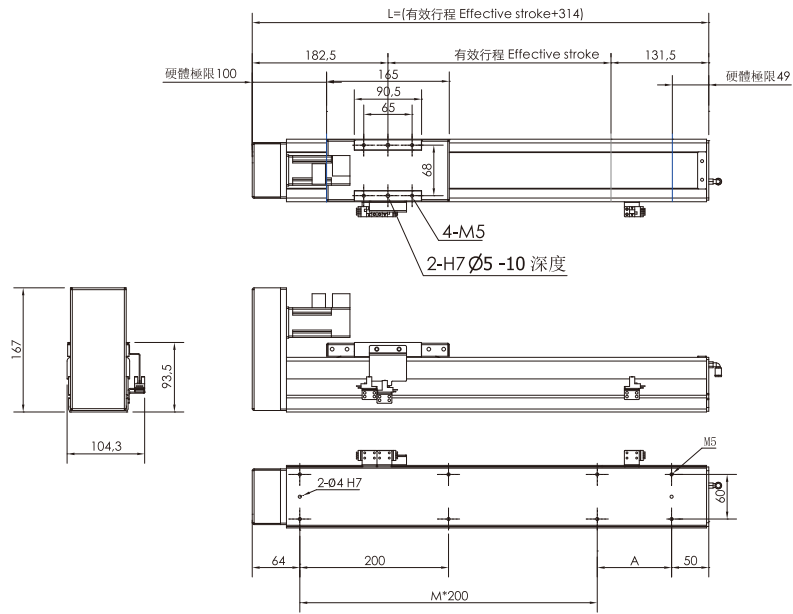

行程	100	150	200	250	300	350	400	450	500	550	600	650	700	750	800	850	900	950	1000	1050
L	414	464	514	564	614	664	714	764	814	864	914	964	1014	1064	1114	1164	1214	1264	1314	1364
A	100	150	200	50	100	150	200	50	100	150	200	50	100	150	200	50	100	150	200	50
M	1	1	1	2	2	2	2	3	3	3	3	4	4	4	4	5	5	5	5	6
N	6	6	6	8	8	8	8	10	10	10	10	12	12	12	12	14	14	14	14	15
重量(kg)	5.0	5.3	5.6	5.9	6.2	6.5	6.8	7.1	7.4	7.7	8.0	8.3	8.6	8.9	9.2	9.5	9.8	10.1	10.4	10.7

※本公司享有變更規格之權益，恕不另行通知 ※Drawings and specifications are subject to change without prior notice.

M6

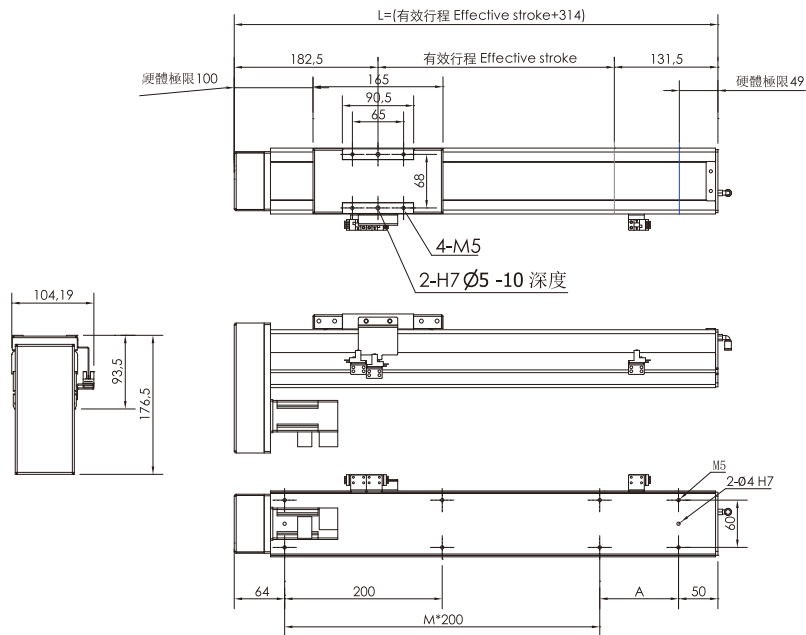

行程	100	150	200	250	300	350	400	450	500	550	600	650	700	750	800	850	900	950	1000	1050
L	414	464	514	564	614	664	714	764	814	864	914	964	1014	1064	1114	1164	1214	1264	1314	1364
A	100	150	200	50	100	150	200	50	100	150	200	50	100	150	200	50	100	150	200	50
M	1	1	1	2	2	2	2	3	3	3	3	4	4	4	4	5	5	5	5	6
N	6	6	6	8	8	8	8	10	10	10	10	12	12	12	12	14	14	14	14	15
重量(kg)	5.0	5.3	5.6	5.9	6.2	6.5	6.8	7.1	7.4	7.7	8.0	8.3	8.6	8.9	9.2	9.5	9.8	10.1	10.4	10.7

※本公司享有變更規格之權益，恕不另行通知 ※Drawings and specifications are subject to change without prior notice.

C100D-YL10 - S1050 - M1 - M 100W - B

型號 Model
 孔型與導程 Hole type and Lead
 行程 Stroke
 馬達方向 Motor direction
 馬達廠牌及出力 Motor brand and output
 煞車 Brake

- Y 底部牙孔 Thread hole
- 馬達方向 Motor direction
- M1 馬達內置 Motor inside position
 - M2 馬達外置 Motor outside position
 - M3 馬達外置右側 Motor outside, rightward position
 - M4 馬達外置左側 Motor outside, leftward position
 - M5 馬達外置上方 Motor outside, upper position
 - M6 馬達外置下方 Motor outside, lower position
- 馬達廠牌及出力 Motor brand and output
- H 上銀 Hiwin
 - X 西門子 Siemens
 - M 三菱 Mitsubishi
 - Y 安川 Yaskawa
 - P 松下 Panasonic
 - F 富士 Fuji
 - T 台達 Delta

C100D規格表(C100D Specification):

線性滑軌12x8-2支

馬達出力 AC Servo motor output(W)	100W				
重覆定位精度 Repeatability(mm)	±0.01				
滾珠螺桿外徑 B.S(Ø)	16	16	16	16	
滾珠螺桿導程 Lead(mm)	5	10	16	20	
最快速度 Maximun speed(mm/sec)	250	500	800	1000	
最大載重 Maximun payload(kg)	水平使用 (H)	50	35	25	20
	垂直使用 (V)	12	10	8	5
額定推力 Rated thrust(N)	300	150	85	75	
行程 Stroke(mm)	100~1050 50 間隔 (interval)				

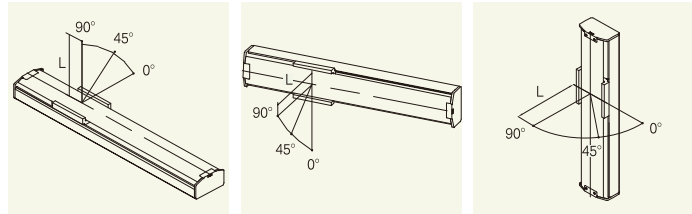

水平安裝應用 (單位:mm)
Horizontal use

導程 Payload	0°	45°	90°
5kg	193	206	467
10kg	72	81	191
20kg	0	0	75
5kg	239	286	536
10kg	119	139	301
25kg	15	23	156
15kg	65	85	225
25kg	21	27	87
35kg	0	0	0
30kg	21	32	262
50kg	1	2	48
60kg	0	0	0

牆面安裝應用 (單位:mm)
Wall installation use

導程 Payload	0°	45°	90°
3kg	462	228	179
17kg	289	94	76
10kg	211	55	39
5kg	477	140	123
10kg	269	78	69
15kg	126	54	37
10kg	545	122	109
20kg	210	33	21
30kg	0	0	0
10kg	602	187	153
20kg	380	92	75
30kg	95	0	0

垂直安裝應用 (單位:mm)
During vertical use

導程 Payload	0°	45°	90°
1kg	546	441	570
3kg	375	243	391
5kg	123	82	150
3kg	413	287	262
5kg	214	151	242
8kg	60	15	85
4kg	296	212	320
6kg	145	102	101
10kg	79	35	80
10kg	93	56	106
13kg	42	32	71
15kg	23	5	41

*滑塊表面中心到搬送物重心的距離(僅供參考)

Distance center of slider top to center of gravity of object being transported (For reference only)

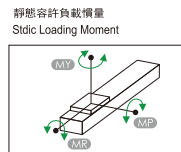

(單位:N.m) [Unit:N.m]
水平使用時 Static Loading Moment

MY	150
MP	150
MR	130

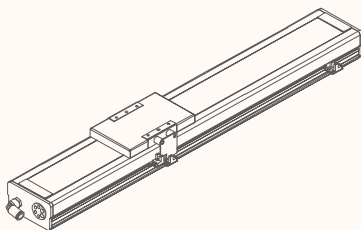

M1

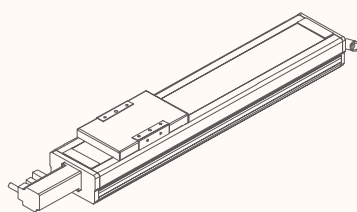

M2

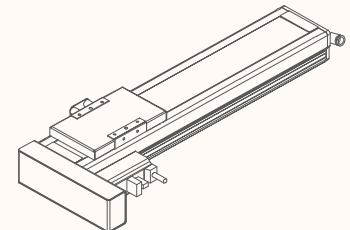

M3

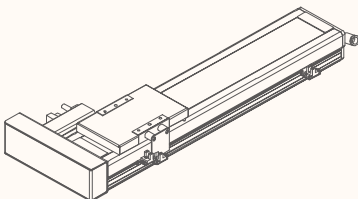

M4

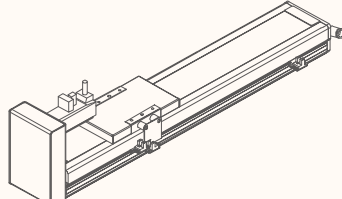

M5

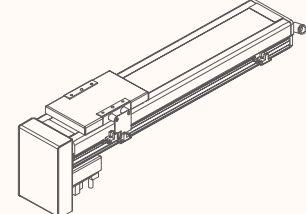

M6

M1

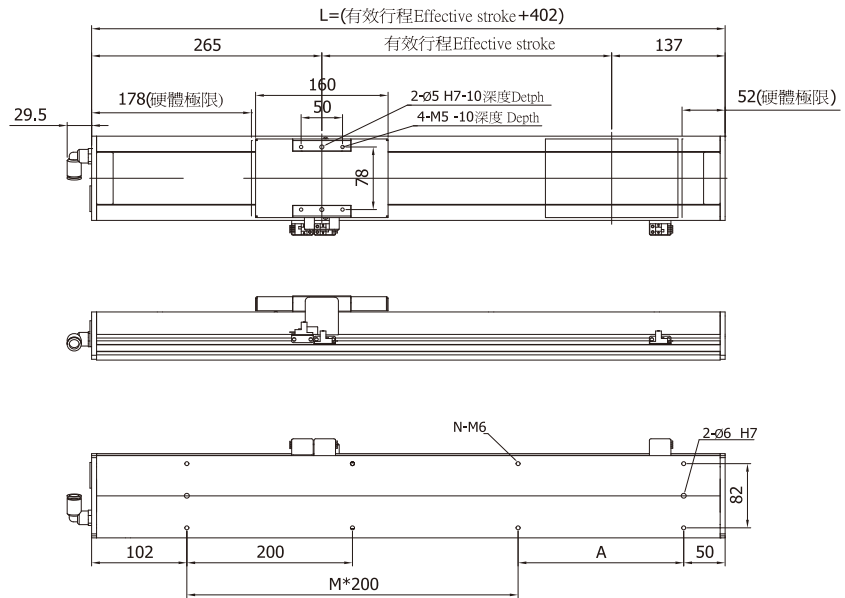
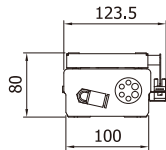

行程	100	150	200	250	300	350	400	450	500	550	600	650	700	750	800	850	900	950	1000	1050
L	502	552	602	652	705	752	802	852	902	952	1002	1052	1102	1152	1202	1252	1302	1352	1402	1452
A	150	200	50	100	150	200	50	100	150	200	50	100	150	200	50	100	150	200	50	100
M	1	1	2	2	2	2	3	3	3	3	4	4	4	4	5	5	5	5	6	6
N	6	6	8	8	8	8	10	10	10	10	12	12	12	12	14	14	14	14	16	16
重量(kg)	5.5	6.0	6.5	7.0	7.5	8.0	8.5	9.0	9.5	10.0	10.5	11.0	11.5	12.0	12.5	13.0	13.5	14.0	14.5	15.0

※本公司享有變更規格之權益，恕不另行通知 ※Drawings and specifications are subject to change without prior notice.

M2

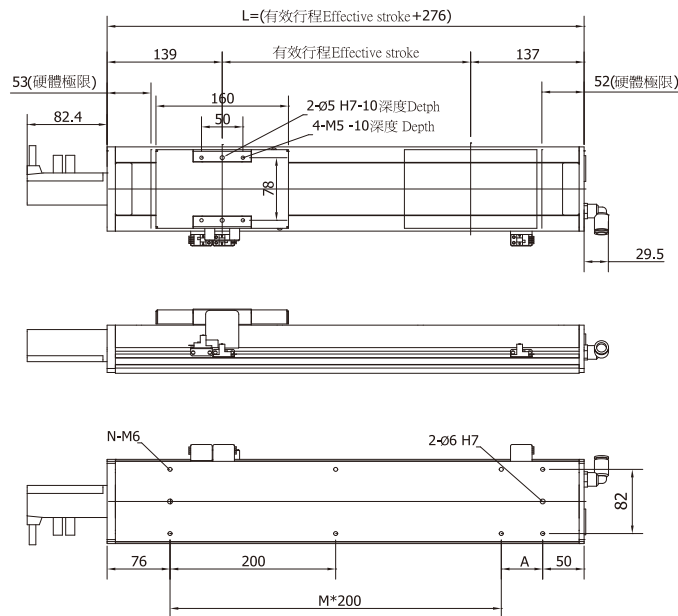
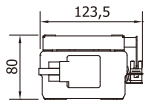

行程	100	150	200	250	300	350	400	450	500	550	600	650	700	750	800	850	900	950	1000	1050
L	376	426	476	526	576	626	676	726	776	826	876	926	976	1026	1076	1126	1176	1226	1276	1326
A	50	100	150	200	50	100	150	200	50	100	150	200	50	100	150	200	50	100	150	200
M	1	1	1	1	2	2	2	2	3	3	3	3	4	4	4	4	5	5	5	5
N	6	6	6	6	8	8	8	8	10	10	10	10	12	12	12	12	14	14	14	14
(kg)	4.8	5.3	5.8	6.3	6.8	7.3	7.8	8.3	8.8	9.3	9.8	10.3	10.8	11.3	11.8	12.3	12.8	13.3	13.8	14.3

※本公司享有變更規格之權益，恕不另行通知 ※Drawings and specifications are subject to change without prior notice.

M3

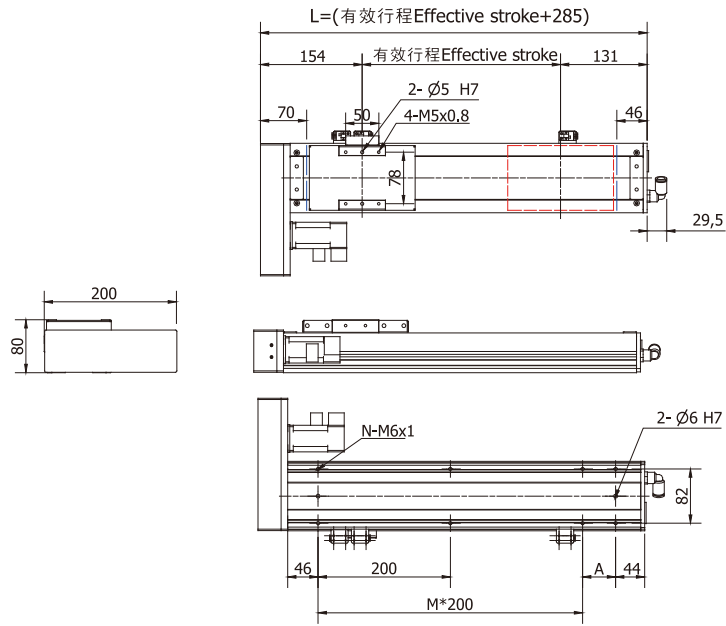

行程	100	150	200	250	300	350	400	450	500	550	600	650	700	750	800	850	900	950	1000	1050
L	376	426	476	526	576	626	676	726	776	826	876	926	976	1026	1076	1126	1176	1226	1276	1326
A	50	100	150	200	50	100	150	200	50	100	150	200	50	100	150	200	50	100	150	200
M	1	1	1	1	2	2	2	2	3	3	3	3	4	4	4	4	5	5	5	5
N	6	6	6	6	8	8	8	8	10	10	10	10	12	12	12	12	14	14	14	14
重量(kg)	5.4	5.9	6.4	6.9	7.4	7.9	8.4	8.9	9.4	9.9	10.4	10.9	11.4	11.9	12.4	12.9	13.4	13.9	14.4	14.9

※本公司享有變更規格之權益，恕不另行通知 ※Drawings and specifications are subject to change without prior notice.

M4

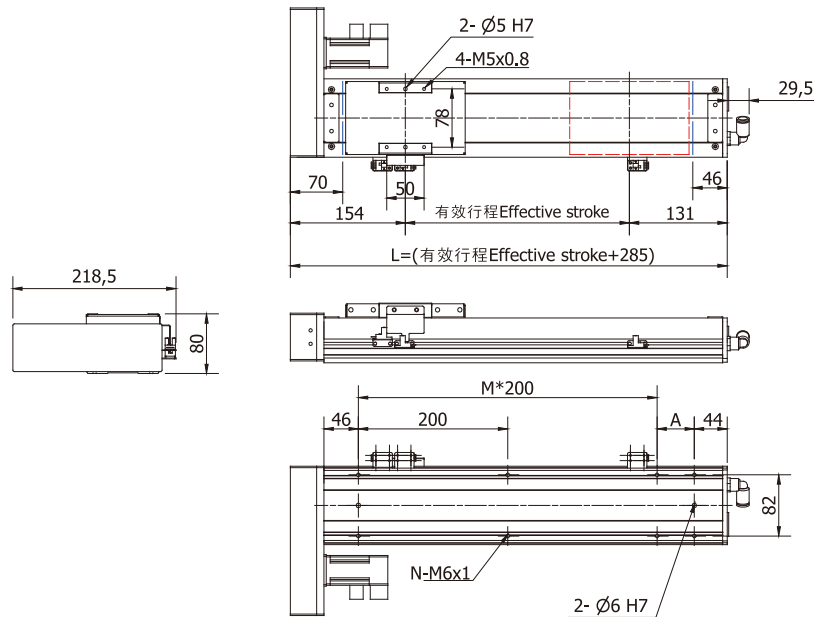

行程	100	150	200	250	300	350	400	450	500	550	600	650	700	750	800	850	900	950	1000	1050
L	376	426	476	526	576	626	676	726	776	826	876	926	976	1026	1076	1126	1176	1226	1276	1326
A	50	100	150	200	50	100	150	200	50	100	150	200	50	100	150	200	50	100	150	200
M	1	1	1	1	2	2	2	2	3	3	3	3	4	4	4	4	5	5	5	5
N	6	6	6	6	8	8	8	8	10	10	10	10	12	12	12	12	14	14	14	14
重量(kg)	5.4	5.9	6.4	6.9	7.4	7.9	8.4	8.9	9.4	9.9	10.4	10.9	11.4	11.9	12.4	12.9	13.4	13.9	14.4	14.9

※本公司享有變更規格之權益，恕不另行通知 ※Drawings and specifications are subject to change without prior notice.

M5

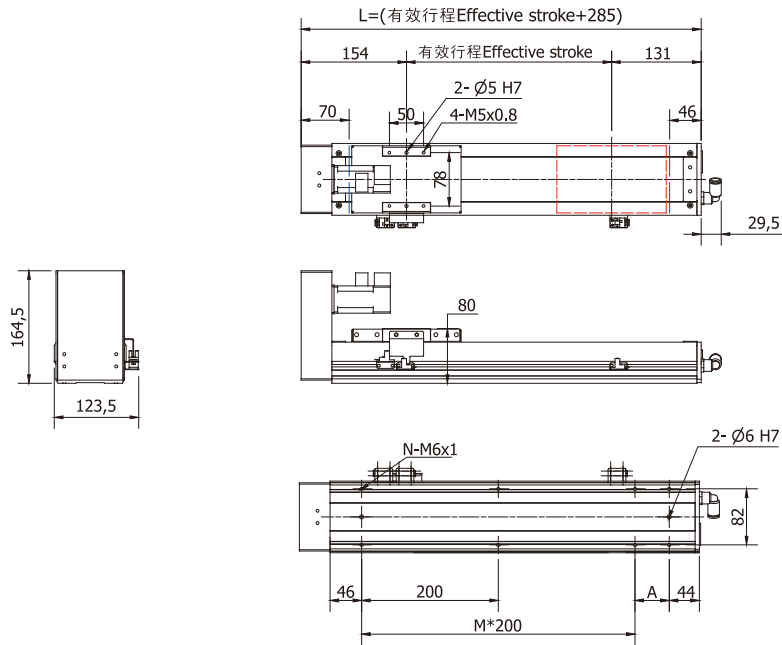

行程	100	150	200	250	300	350	400	450	500	550	600	650	700	750	800	850	900	950	1000	1050
L	376	426	476	526	576	626	676	726	776	826	876	926	976	1026	1076	1126	1176	1226	1276	1326
A	50	100	150	200	50	100	150	200	50	100	150	200	50	100	150	200	50	100	150	200
M	1	1	1	1	2	2	2	2	3	3	3	3	4	4	4	4	5	5	5	5
N	6	6	6	6	8	8	8	8	10	10	10	10	12	12	12	12	14	14	14	14
重量(kg)	5.4	5.9	6.4	6.9	7.4	7.9	8.4	8.9	9.4	9.9	10.4	10.9	11.4	11.9	12.4	12.9	13.4	13.9	14.4	14.9

※本公司享有變更規格之權益，恕不另行通知 ※Drawings and specifications are subject to change without prior notice.

M6

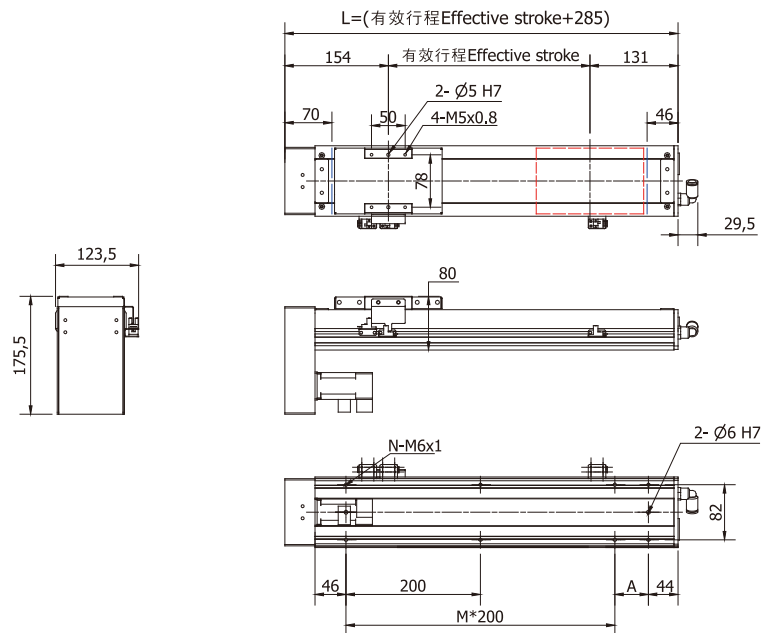

行程	100	150	200	250	300	350	400	450	500	550	600	650	700	750	800	850	900	950	1000	1050
L	376	426	476	526	576	626	676	726	776	826	876	926	976	1026	1076	1126	1176	1226	1276	1326
A	50	100	150	200	50	100	150	200	50	100	150	200	50	100	150	200	50	100	150	200
M	1	1	1	1	2	2	2	2	3	3	3	3	4	4	4	4	5	5	5	5
N	6	6	6	6	8	8	8	8	10	10	10	10	12	12	12	12	14	14	14	14
重量(kg)	5.4	5.9	6.4	6.9	7.4	7.9	8.4	8.9	9.4	9.9	10.4	10.9	11.4	11.9	12.4	12.9	13.4	13.9	14.4	14.9

※本公司享有變更規格之權益，恕不另行通知 ※Drawings and specifications are subject to change without prior notice.

C136D-YL10 - S1050 - M1 - M 200W - B

型號 Model 孔型與導程 Hole type and Lead 行程 Stroke 馬達方向 Motor direction 馬達廠牌及出力 Motor brand and output 煞車 Brake

Y 底部牙孔
Thread hole

馬達方向 Motor direction

- M1 馬達內置 Motor inside position
- M2 馬達外置 Motor outside position
- M3 馬達外置右側 Motor outside, rightward position
- M4 馬達外置左側 Motor outside, leftward position
- M5 馬達外置上方 Motor outside, upper position
- M6 馬達外置下方 Motor outside, lower position

馬達廠牌及出力 Motor brand and output

- H 上銀 Hiwin
- X 西門子 Siemens
- M 三菱 Mitsubishi
- Y 安川 Yaskawa
- P 松下 Panasonic
- F 富士 Fuji
- T 台達 Delta

C136D規格表(C136D Specification):

馬達出力 AC Servo motor output(W)	200W				
重覆定位精度 Repeatability(mm)	±0.01				
滾珠螺桿外徑 B.S(Ø)	16	16	16	20	
滾珠螺桿導程 Lead(mm)	5	10	16	20	
最快速度 Maximun speed(mm/sec)	250	500	800	1000	
最大載重 Maximun payload(kg)	水平使用 (H)	80	70	65	35
	垂直使用 (V)	25	20	15	8
額定推力 Rated thrust(N)	640	320	225	160	
行程 Stroke(mm)	100~1050 50 間隔 (interval)				

線性滑軌15x12.5-2支

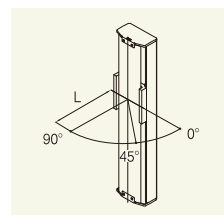
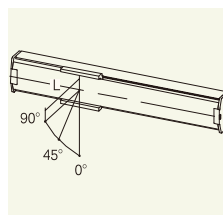
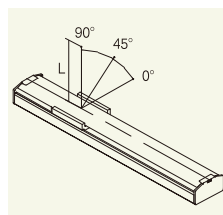

水平安裝應用(單位:mm)
Horizontal use

導程 Payload	荷重 Payload	0°	45°	90°
Lead 20	10kg	820	870	1830
	20kg	450	480	1050
	35kg	250	310	650
Lead 16	30kg	360	470	1100
	50kg	232	315	815
	65kg	159	222	705
Lead 10	40kg	331	459	1027
	55kg	215	299	797
	70kg	154	219	680
Lead 5	60kg	185	329	1625
	73kg	154	262	1385
	85kg	134	219	1220

牆面安裝應用(單位:mm)
Wall installation use

導程 Payload	荷重 Payload	0°	45°	90°
Lead 20	10kg	935	499	550
	20kg	526	288	290
	30kg	305	130	125
	30kg	1030	340	272
Lead 16	50kg	659	160	119
	60kg	398	40	29
	40kg	525	166	86
	55kg	385	92	13
Lead 10	70kg	121	6	0
	60kg	725	61	40
	70kg	349	11	7
Lead 5	80kg	0	0	0

垂直安裝應用(單位:mm)
During vertical use

導程 Payload	荷重 Payload	0°	45°	90°
Lead 20	4kg	609	830	1423
	6kg	470	559	952
	8kg	350	411	713
Lead 16	10kg	400	568	1121
	13kg	270	375	705
	15kg	201	261	529
Lead 10	15kg	149	215	431
	18kg	115	161	349
	20kg	95	135	273
Lead 5	20kg	166	221	393
	22kg	127	190	310
	25kg	73	108	263

*滑塊表面中心到搬送物重心的距離(僅供參考)
Distance center of slider top to center of gravity of object being transported (For reference only)

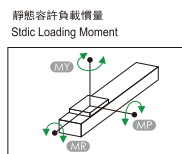

(單位:N.m) (Unit:N.m)	水平使用時 Static Loading Moment
MY	551
MP	552
MR	485

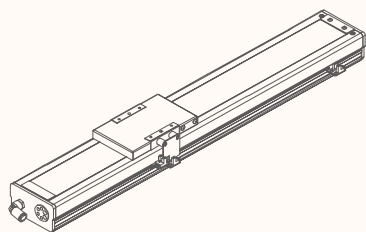

M1

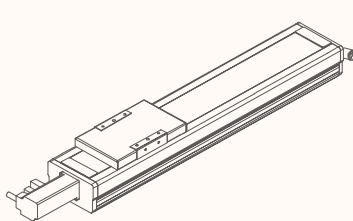

M2

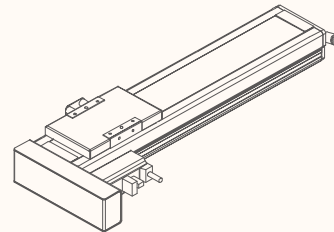

M3

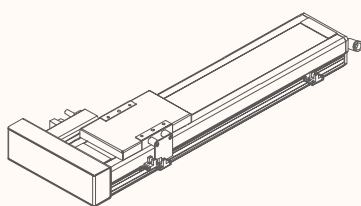

M4

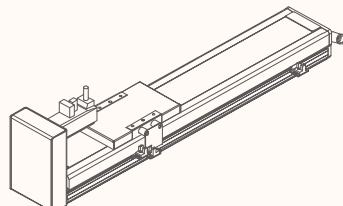

M5

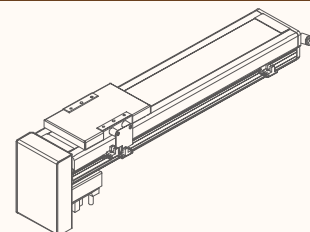

M6

M1

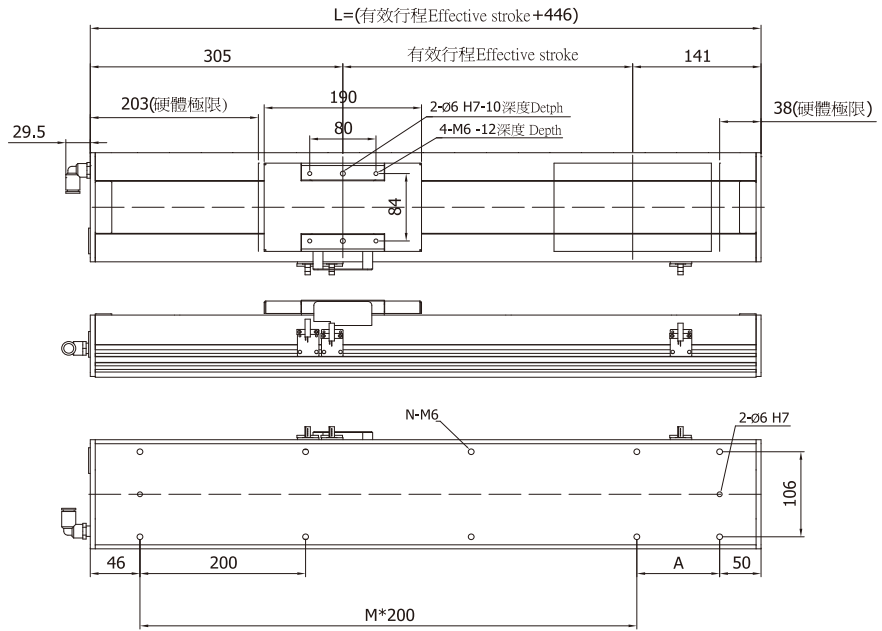
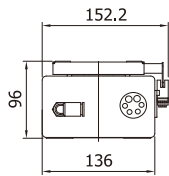

行程	100	150	200	250	300	350	400	450	500	550	600	650	700	750	800	850	900	950	1000	1050
L	546	596	646	696	746	796	846	896	946	996	1046	1096	1146	1196	1246	1296	1346	1396	1446	1496
A	50	100	150	200	50	100	150	200	50	100	150	200	50	100	150	200	50	100	150	200
M	2	2	2	2	3	3	3	3	4	4	4	4	5	5	5	5	6	6	6	6
N	8	8	8	8	10	10	10	10	12	12	12	12	14	14	14	14	14	14	16	16
重量(kg)	8.5	9.0	9.5	10.0	10.5	11.0	11.5	12.0	12.5	13.0	13.5	14.0	14.5	15.0	15.5	16.0	16.5	17.0	17.5	18.0

※本公司享有變更規格之權益，恕不另行通知 ※Drawings and specifications are subject to change without prior notice.

M2

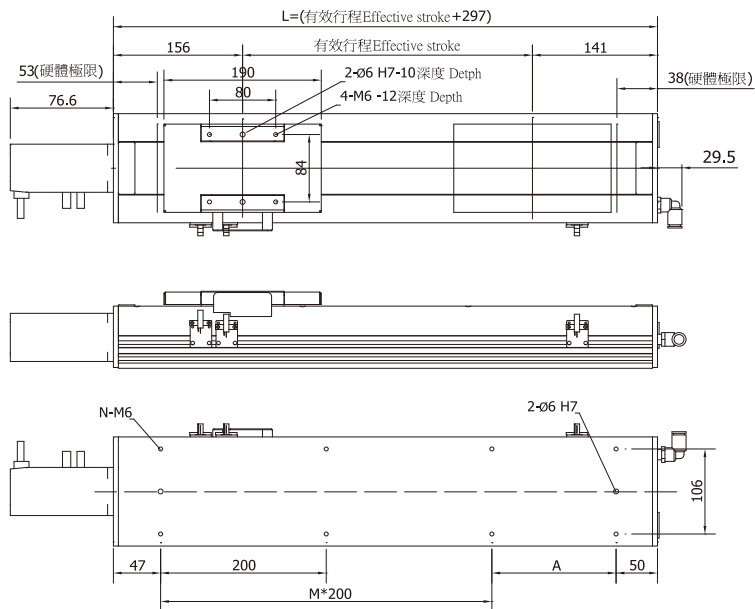
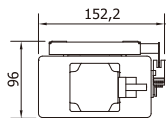

行程	100	150	200	250	300	350	400	450	500	550	600	650	700	750	800	850	900	950	1000	1050
L	397	447	497	547	597	647	697	747	797	847	897	947	997	1047	1097	1147	1197	1247	1297	1347
A	100	150	200	50	100	150	200	50	100	150	200	50	100	150	200	50	100	150	200	50
M	1	1	1	2	2	2	2	3	3	3	3	4	4	4	4	5	5	5	5	6
N	6	6	6	8	8	8	8	10	10	10	10	12	12	12	12	14	14	14	14	16
重量(kg)	7.7	8.2	8.7	9.2	9.7	10.2	10.7	11.2	11.7	12.2	12.7	13.2	13.7	14.2	14.7	15.2	15.7	16.2	16.7	17.2

※本公司享有變更規格之權益，恕不另行通知 ※Drawings and specifications are subject to change without prior notice.

M3

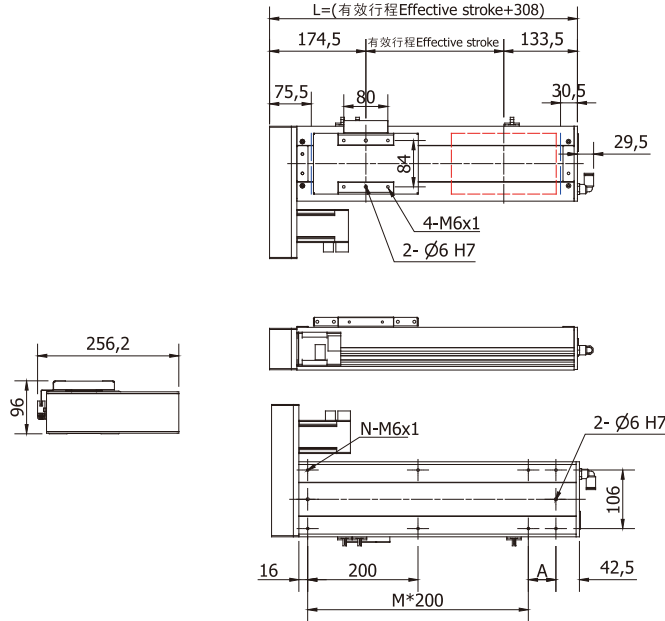

行程	100	150	200	250	300	350	400	450	500	550	600	650	700	750	800	850	900	950	1000	1050
L	408	458	508	558	608	658	708	758	808	858	908	958	1008	1058	1108	1058	1208	1258	1308	1358
A	100	150	200	50	100	150	200	50	100	150	200	50	100	150	200	50	100	150	200	50
M	1	1	1	2	2	2	2	3	3	3	3	4	4	4	4	5	5	5	5	6
N	6	6	6	8	8	8	8	10	10	10	10	12	12	12	12	14	14	14	14	16
重量(kg)	7.4	7.9	8.4	8.9	9.4	9.9	10.4	10.9	11.4	11.9	12.4	12.7	13.4	13.9	14.4	14.9	15.4	15.9	16.4	16.9

※本公司享有變更規格之權益，恕不另行通知 ※Drawings and specifications are subject to change without prior notice.

M4

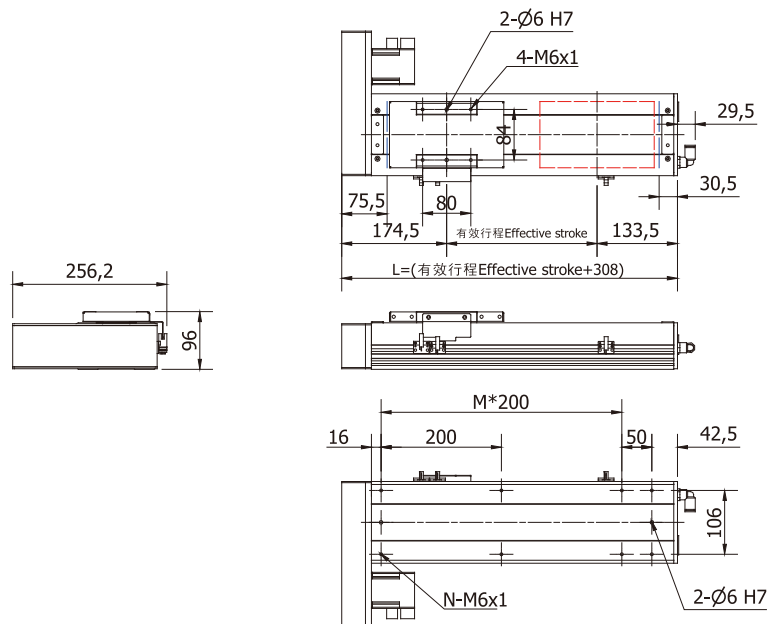

行程	100	150	200	250	300	350	400	450	500	550	600	650	700	750	800	850	900	950	1000	1050
L	408	458	508	558	608	658	708	758	808	858	908	958	1008	1058	1108	1058	1208	1258	1308	1358
A	100	150	200	50	100	150	200	50	100	150	200	50	100	150	200	50	100	150	200	50
M	1	1	1	2	2	2	2	3	3	3	3	4	4	4	4	5	5	5	5	6
N	6	6	6	8	8	8	8	10	10	10	10	12	12	12	12	14	14	14	14	16
重量(kg)	7.4	7.9	8.4	8.9	9.4	9.9	10.4	10.9	11.4	11.9	12.4	12.7	13.4	13.9	14.4	14.9	15.4	15.9	16.4	16.9

※本公司享有變更規格之權益，恕不另行通知 ※Drawings and specifications are subject to change without prior notice.

M5

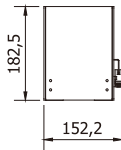
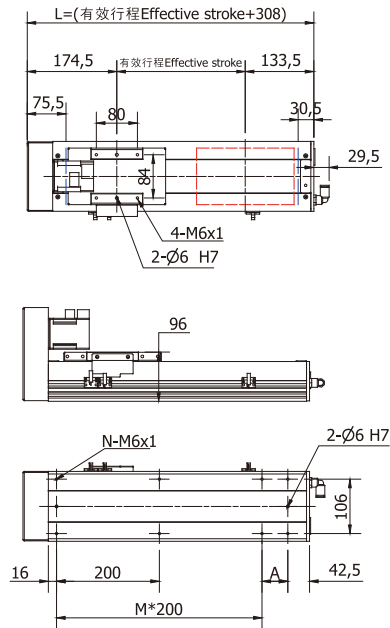

行程	100	150	200	250	300	350	400	450	500	550	600	650	700	750	800	850	900	950	1000	1050
L	408	458	508	558	608	658	708	758	808	858	908	958	1008	1058	1108	1058	1208	1258	1308	1358
A	100	150	200	50	100	150	200	50	100	150	200	50	100	150	200	50	100	150	200	50
M	1	1	1	2	2	2	2	3	3	3	3	4	4	4	4	5	5	5	5	6
N	6	6	6	8	8	8	8	10	10	10	10	12	12	12	12	14	14	14	14	16
重量(kg)	7.4	7.9	8.4	8.9	9.4	9.9	10.4	10.9	11.4	11.9	12.4	12.7	13.4	13.9	14.4	14.9	15.4	15.9	16.4	16.9

※本公司享有變更規格之權益，恕不另行通知 ※Drawings and specifications are subject to change without prior notice.

M6

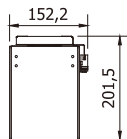
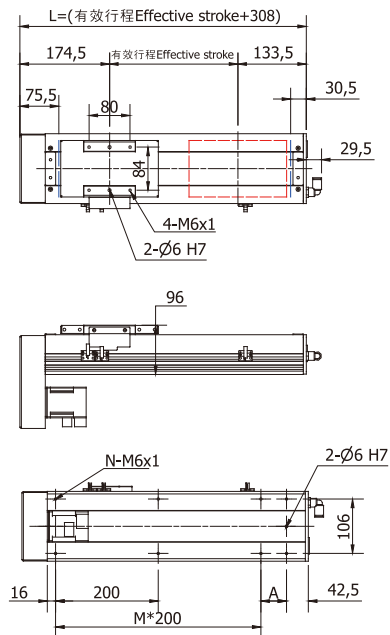

行程	100	150	200	250	300	350	400	450	500	550	600	650	700	750	800	850	900	950	1000	1050
L	408	458	508	558	608	658	708	758	808	858	908	958	1008	1058	1108	1058	1208	1258	1308	1358
A	100	150	200	50	100	150	200	50	100	150	200	50	100	150	200	50	100	150	200	50
M	1	1	1	2	2	2	2	3	3	3	3	4	4	4	4	5	5	5	5	6
N	6	6	6	8	8	8	8	10	10	10	10	12	12	12	12	14	14	14	14	16
重量(kg)	7.4	7.9	8.4	8.9	9.4	9.9	10.4	10.9	11.4	11.9	12.4	12.7	13.4	13.9	14.4	14.9	15.4	15.9	16.4	16.9

※本公司享有變更規格之權益，恕不另行通知 ※Drawings and specifications are subject to change without prior notice.

C168D-YL10 - S1250 - M1 - M 400W - B

型號 Model
 孔型與導程 Hole type and Lead
 行程 Stroke
 馬達方向 Motor direction
 馬達廠牌及出力 Motor brand and output
 煞車 Brake

Y 底部牙孔
Thread hole

馬達方向 Motor direction

- M1 馬達內置 Motor inside position
- M2 馬達外置 Motor outside position
- M3 馬達外置右側 Motor outside, rightward position
- M4 馬達外置左側 Motor outside, leftward position
- M5 馬達外置上方 Motor outside, upper position
- M6 馬達外置下方 Motor outside, lower position

馬達廠牌及出力 Motor brand and output

- H 上銀 Hiwin
- X 西門子 Siemens
- M 三菱 Mitsubishi
- Y 安川 Yaskawa
- P 松下 Panasonic
- F 富士 Fuji
- T 台達 Delta

C168D規格表(C168D Specification):

線性滑軌20x15.5-2支

馬達出力 AC Servo motor output(W)	400W				
重覆定位精度 Repeatability(mm)	±0.01				
滾珠螺桿外徑 B.S(Ø)	20	20	20	25	
滾珠螺桿導程 Lead(mm)	5	10	20	25	
最快速度 Maximun speed(mm/sec)	250	500	1000	1250	
最大載重 Maximun payload(kg)	水平使用 (H)	110	80	75	65
	垂直使用 (V)	40	35	15	11
額定推力 Rated thrust(N)	945	480	240	200	
行程 Stroke(mm)	100~1250 50 間隔(interval)				

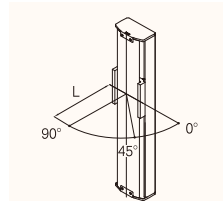
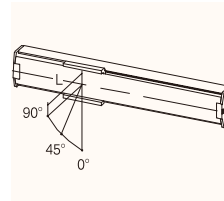
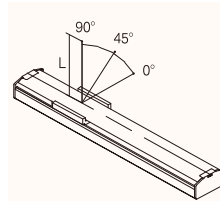

導程 Payload	荷重 Payload	0°	45°	90°
Lead 25	25kg	643	867	1438
	45kg	399	512	1103
	65kg	240	336	971
Lead 20	30kg	765	922	1749
	50kg	454	571	1216
	75kg	305	393	1035
Lead 10	50kg	661	808	1371
	65kg	499	573	1190
	80kg	337	428	1007
Lead 5	70kg	389	530	1398
	90kg	220	312	1089
	110kg	180	250	950

導程 Payload	荷重 Payload	0°	45°	90°
Lead 25	25kg	979	460	431
	45kg	682	312	300
	65kg	566	203	171
Lead 20	30kg	1095	560	550
	50kg	730	335	325
	75kg	580	215	195
Lead 10	50kg	1212	478	369
	65kg	1130	384	335
	80kg	973	263	220
Lead 5	70kg	911	400	365
	90kg	622	249	197
	110kg	464	176	110

導程 Payload	荷重 Payload	0°	45°	90°
Lead 25	3kg	2544	1789	2544
	7kg	1383	672	1383
	11kg	900	571	900
Lead 20	5kg	2350	1660	2350
	10kg	1210	845	1210
	15kg	810	570	810
Lead 10	15kg	1610	1138	1610
	25kg	950	670	950
	35kg	660	468	660
Lead 5	20kg	1577	1099	1577
	30kg	782	567	782
	40kg	245	130	245

*滑塊表面中心到搬送物重心的距離(僅供參考)
Distance center of slider top to center of gravity of object being transported (For reference only)

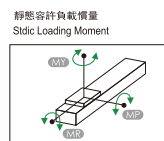

MY	2052
MP	2052
MR	1810

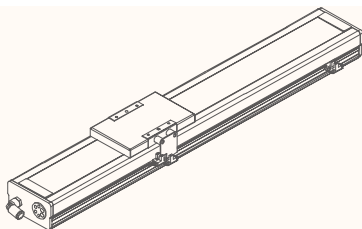

M1

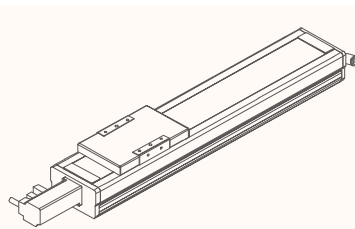

M2

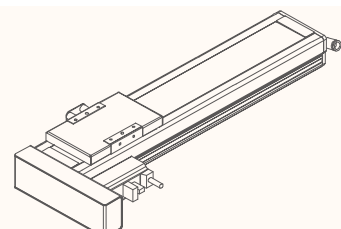

M3

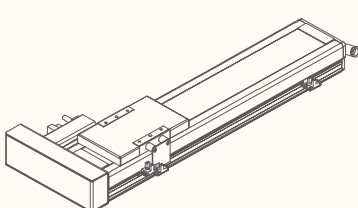

M4

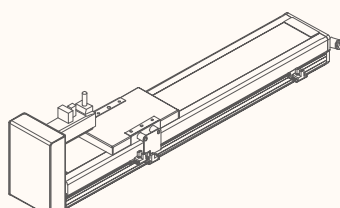

M5

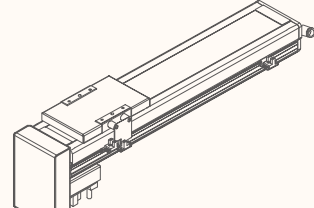

M6

M1

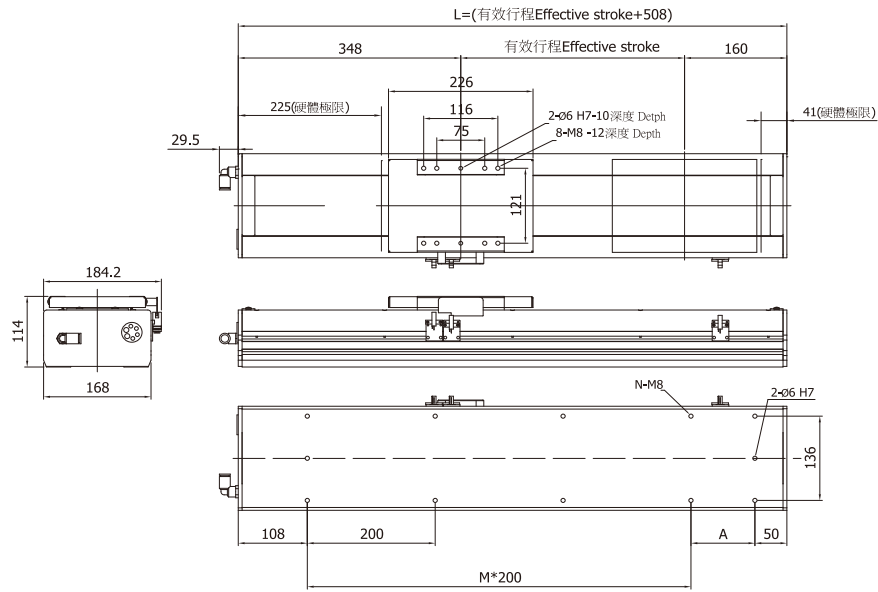

行程	100	150	200	250	300	350	400	450	500	550	600	650	700	750	800	850	900	950	1000	1050	1100	1150	1200	1250
L	608	658	708	758	808	858	908	958	1008	1058	1108	1158	1208	1258	1308	1358	1408	1458	1508	1558	1608	1658	1708	1758
A	50	100	150	200	50	100	150	200	50	100	150	200	50	100	150	200	50	100	150	200	50	100	150	200
M	2	2	2	2	3	3	3	3	4	4	4	4	5	5	5	5	6	6	6	6	7	7	7	7
N	8	8	8	8	10	10	10	10	12	12	12	12	14	14	14	14	16	16	16	16	18	18	18	18
重量(kg)	16.6	17.6	18.6	19.6	20.6	21.6	22.6	23.6	24.6	25.6	26.6	27.6	28.6	29.6	30.6	31.6	32.6	33.6	35.6	35.6	36.6	37.6	38.6	39.6

※本公司享有變更規格之權益，恕不另行通知 ※Drawings and specifications are subject to change without prior notice.

M2

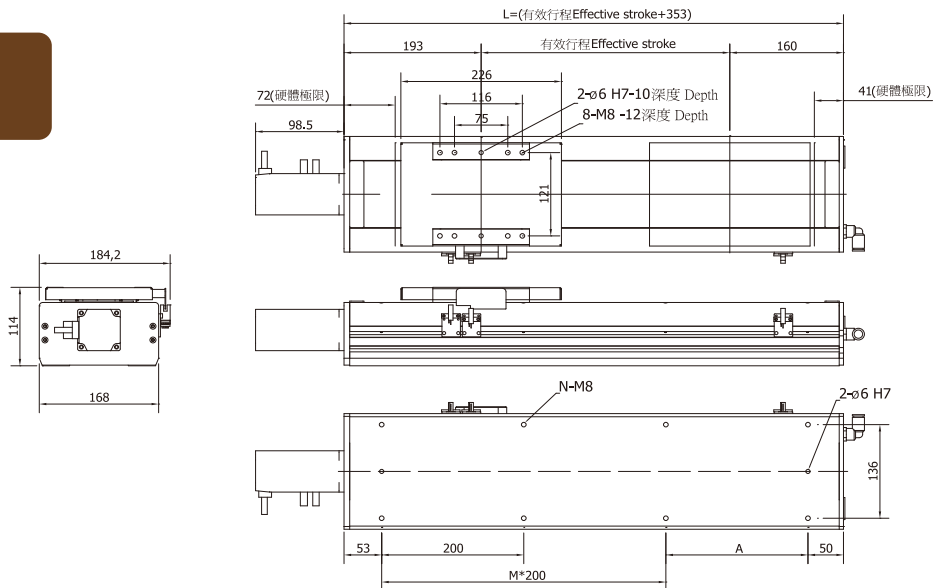

行程	100	150	200	250	300	350	400	450	500	550	600	650	700	750	800	850	900	950	1000	1050	1100	1150	1200	1250
L	453	503	553	603	653	708	753	803	853	903	953	1003	1053	1103	1153	1208	1253	1303	1353	1403	1458	1503	1553	1603
A	150	200	50	100	150	200	50	100	150	200	50	100	150	200	50	100	150	200	50	100	150	200	50	100
M	1	1	2	2	2	2	3	3	3	3	4	4	4	4	5	5	5	5	6	6	6	6	7	7
N	6	6	8	8	8	8	10	10	10	10	12	12	12	12	14	14	14	14	16	16	16	16	18	18
重量(kg)	14.0	15.0	16.0	17.0	18.0	19.0	20.0	21.0	22.0	23.0	24.0	25.0	26.0	27.0	28.0	29.0	30.0	31.0	32.0	33.0	34.0	35.0	36.0	37.0

※本公司享有變更規格之權益，恕不另行通知 ※Drawings and specifications are subject to change without prior notice.

M3

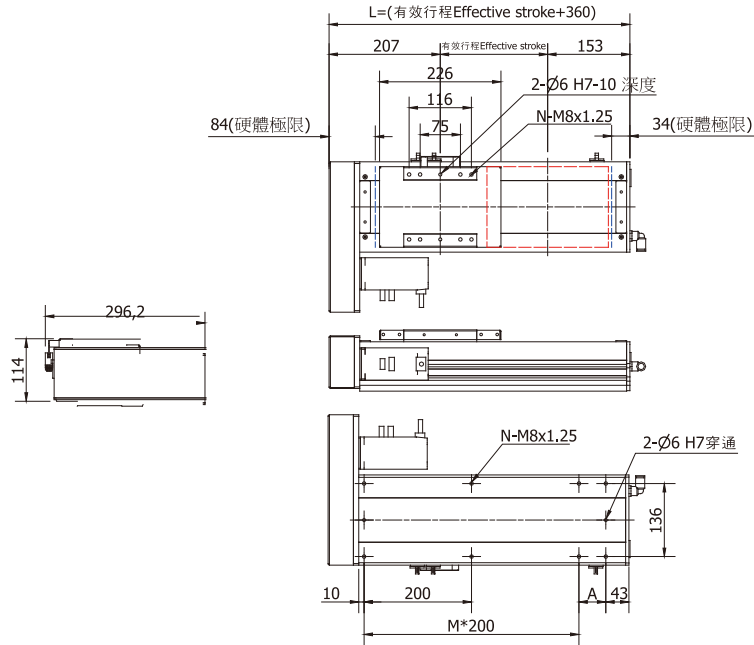

行程	100	150	200	250	300	350	400	450	500	550	600	650	700	750	800	850	900	950	1000	1050	1100	1150	1200	1250
L	460	510	560	610	660	710	760	810	860	910	960	1010	1060	1110	1160	1210	1260	1310	1360	1410	1460	1510	1560	1610
A	150	200	50	100	150	200	50	100	150	200	50	100	150	200	50	100	150	200	50	100	150	200	50	100
M	1	1	2	2	2	2	3	3	3	3	4	4	4	4	5	5	5	5	6	6	6	6	7	7
N	6	6	8	8	8	8	10	10	10	10	12	12	12	12	14	14	14	14	16	16	16	16	18	18
重量(kg)	15.4	16.4	17.4	18.4	19.4	20.4	21.4	22.4	23.4	24.4	25.4	26.4	27.4	28.4	29.4	30.4	31.4	32.4	33.4	34.4	35.4	36.4	37.4	38.4

※本公司享有變更規格之權益，恕不另行通知 ※Drawings and specifications are subject to change without prior notice.

M4

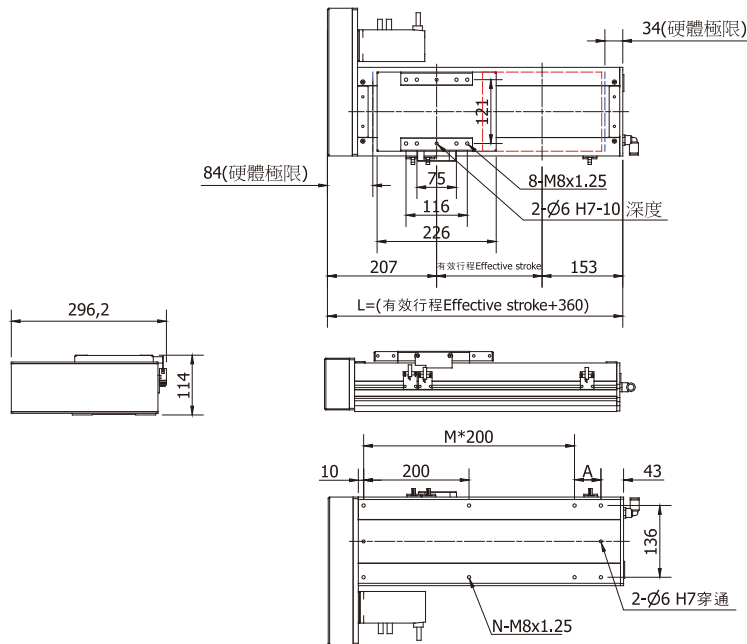

行程	100	150	200	250	300	350	400	450	500	550	600	650	700	750	800	850	900	950	1000	1050	1100	1150	1200	1250
L	460	510	560	610	660	710	760	810	860	910	960	1010	1060	1110	1160	1210	1260	1310	1360	1410	1460	1510	1560	1610
A	150	200	50	100	150	200	50	100	150	200	50	100	150	200	50	100	150	200	50	100	150	200	50	100
M	1	1	2	2	2	2	3	3	3	3	4	4	4	4	5	5	5	5	6	6	6	6	7	7
N	6	6	8	8	8	8	10	10	10	10	12	12	12	12	14	14	14	14	16	16	16	16	18	18
重量(kg)	15.4	16.4	17.4	18.4	19.4	20.4	21.4	22.4	23.4	24.4	25.4	26.4	27.4	28.4	29.4	30.4	31.4	32.4	33.4	34.4	35.4	36.4	37.4	38.4

※本公司享有變更規格之權益，恕不另行通知 ※Drawings and specifications are subject to change without prior notice.

M5

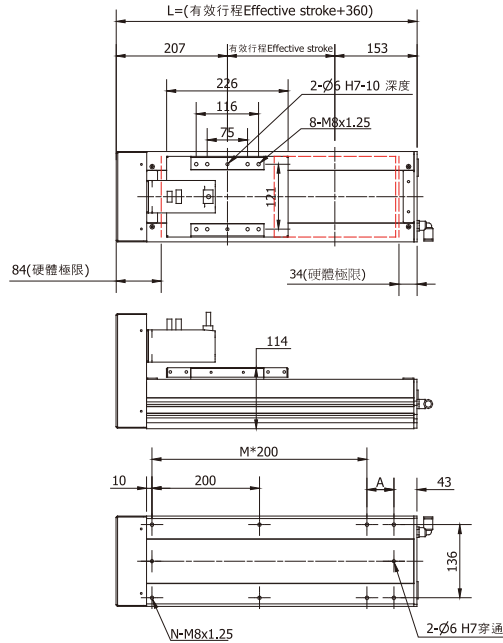
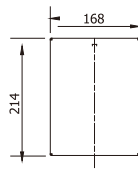

行程	100	150	200	250	300	350	400	450	500	550	600	650	700	750	800	850	900	950	1000	1050	1100	1150	1200	1250
L	460	510	560	610	660	710	760	810	860	910	960	1010	1060	1110	1160	1210	1260	1310	1360	1410	1460	1510	1560	1610
A	150	200	50	100	150	200	50	100	150	200	50	100	150	200	50	100	150	200	50	100	150	200	50	100
M	1	1	2	2	2	2	3	3	3	3	4	4	4	4	5	5	5	5	6	6	6	6	7	7
N	6	6	8	8	8	8	10	10	10	10	12	12	12	12	14	14	14	14	16	16	16	16	18	18
重量(kg)	15.4	16.4	17.4	18.4	19.4	20.4	21.4	22.4	23.4	24.4	25.4	26.4	27.4	28.4	29.4	30.4	31.4	32.4	33.4	34.4	35.4	36.4	37.4	38.4

※本公司享有變更規格之權益，恕不另行通知 ※Drawings and specifications are subject to change without prior notice.

M6

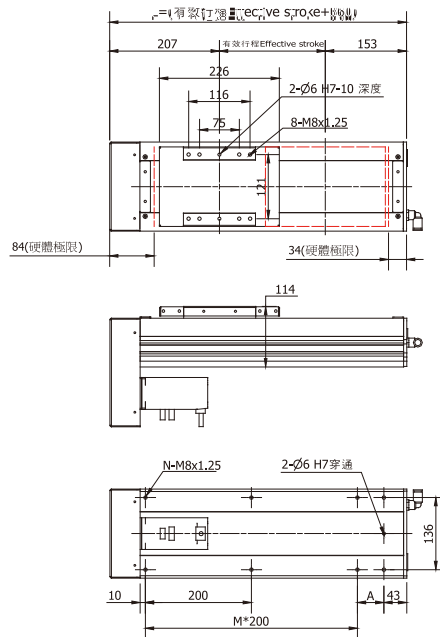
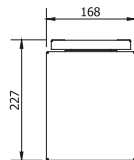

行程	100	150	200	250	300	350	400	450	500	550	600	650	700	750	800	850	900	950	1000	1050	1100	1150	1200	1250
L	460	510	560	610	660	710	760	810	860	910	960	1010	1060	1110	1160	1210	1260	1310	1360	1410	1460	1510	1560	1610
A	150	200	50	100	150	200	50	100	150	200	50	100	150	200	50	100	150	200	50	100	150	200	50	100
M	1	1	2	2	2	2	3	3	3	3	4	4	4	4	5	5	5	5	6	6	6	6	7	7
N	6	6	8	8	8	8	10	10	10	10	12	12	12	12	14	14	14	14	16	16	16	16	18	18
重量(kg)	15.4	16.4	17.4	18.4	19.4	20.4	21.4	22.4	23.4	24.4	25.4	26.4	27.4	28.4	29.4	30.4	31.4	32.4	33.4	34.4	35.4	36.4	37.4	38.4

※本公司享有變更規格之權益，恕不另行通知 ※Drawings and specifications are subject to change without prior notice.

C202D-YL10 - S1450 - M1 - M 750W - B

型號 Model
 孔型與導程 Hole type and Lead
 行程 Stroke
 馬達方向 Motor direction
 馬達廠牌及出力 Motor brand and output
 煞車 Brake

Y 底部牙孔
Thread hole

馬達方向 Motor direction

- M1 馬達內置 Motor inside position
- M2 馬達外置 Motor outside position
- M3 馬達外置右側 Motor outside, rightward position
- M4 馬達外置左側 Motor outside, leftward position
- M5 馬達外置上方 Motor outside, upper position
- M6 馬達外置下方 Motor outside, lower position

馬達廠牌及出力 Motor brand and output

- H 上銀 Hiwin
- X 西門子 Siemens
- M 三菱 Mitsubishi
- Y 安川 Yaskawa
- P 松下 Panasonic
- F 富士 Fuji
- T 台達 Delta

C202D規格表(C202D Specification):

馬達出力 AC Servo motor output(W)	750W					
重覆定位精度 Repeatability(mm)	±0.01					
滾珠螺桿外徑 B.S(Ø)	25	25	32	25	32	
滾珠螺桿導程 Lead(mm)	5	10	20	25	32	
最快速度 Maximum speed(mm/sec)	250	500	1000	1250	1600	
最大載重 Maximum payload(kg)	水平使用 (H)	120	100	85	75	65
	垂直使用 (V)	55	45	25	23	20
額定推力 Rated thrust(N)	2050	1025	560	420	350	
行程 Stroke(mm)	100~1450 50 間隔(interval)					

線性滑軌23x22-2支

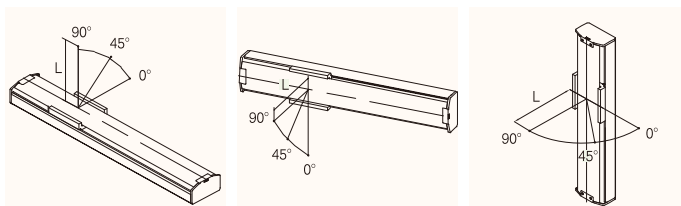

水平安裝應用(單位:mm)
Horizontal use

導程 Lead	荷重 Payload	0°	45°	90°
Lead 32	45kg	223	393	835
	55kg	482	603	1008
	65kg	189	244	525
Lead 20	50kg	765	922	1449
	70kg	454	571	1216
	85kg	305	393	935
Lead 10	60kg	603	770	1493
	80kg	400	511	1236
	100kg	188	243	1019
Lead 5	85kg	408	539	1366
	100kg	227	291	1078
	120kg	83	100	904

牆面安裝應用(單位:mm)
Wall installation use

導程 Lead	荷重 Payload	0°	45°	90°
Lead 32	45kg	700	354	412
	55kg	543	235	325
	65kg	399	141	235
Lead 20	50kg	1305	601	588
	70kg	1002	427	397
	85kg	731	298	265
Lead 10	60kg	1095	531	502
	80kg	737	430	378
	100kg	581	237	195
Lead 5	85kg	987	421	387
	100kg	645	303	216
	120kg	412	157	89

垂直安裝應用(單位:mm)
During vertical use

導程 Lead	荷重 Payload	0°	45°	90°
Lead 32	10kg	1175	802	1175
	15kg	893	560	893
	20kg	531	278	531
Lead 20	15kg	1270	903	1270
	20kg	876	678	876
	25kg	753	468	753
Lead 10	20kg	1810	1238	1810
	30kg	1152	791	1152
	45kg	713	564	713
Lead 5	30kg	979	631	979
	40kg	669	370	669
	55kg	222	48	222

*滑塊表面中心到搬送物重心的距離(僅供參考)
Distance center of slider top to center of gravity of object being transported (For reference only)

靜態容許負載橫量
Static Loading Moment

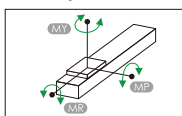

(單位:N.m) [Unit:N.m]
水平使用時 Static Loading Moment

MY	2025
MP	2025
MR	1810

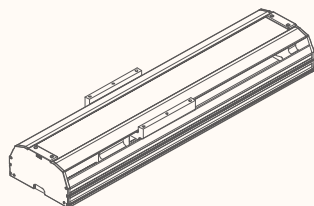

M1

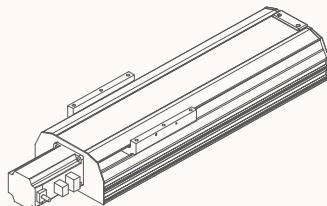

M2

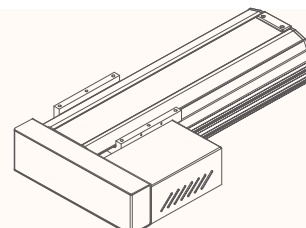

M3

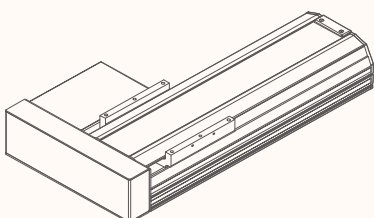

M4

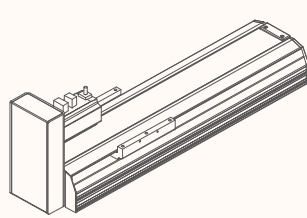

M5

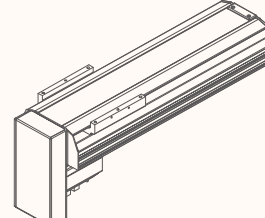

M6

M1

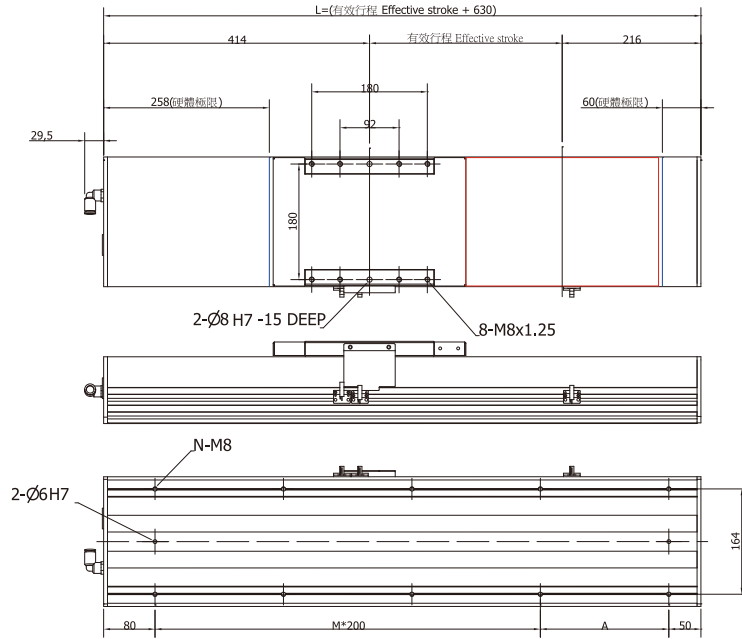
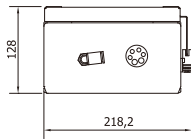

行程	100	150	200	250	300	350	400	450	500	550	600	650	700	750	800	850	900	950	1000	1050	1100	1150	1200	1250	1300	1350	1400	1450
L	730	780	830	880	930	980	1030	1080	1130	1180	1230	1280	1330	1380	1430	1480	1530	1580	1630	1680	1730	1780	1830	1880	1930	1980	2030	2080
A	200	50	100	150	200	50	100	150	200	50	100	150	200	50	100	150	200	50	100	150	200	50	100	150	200	50	100	150
M	2	3	3	3	3	4	4	4	4	5	5	5	5	6	6	6	6	7	7	7	7	8	8	8	8	9	9	9
N	8	10	10	10	10	12	12	12	12	14	14	14	14	16	16	16	16	18	18	18	18	20	20	20	20	22	22	22
重量(kg)	30.3	31.8	33.3	34.8	36.3	37.8	39.3	40.8	42.3	43.8	45.3	46.8	48.3	49.8	51.3	52.8	54.3	55.8	57.3	58.8	60.3	61.8	63.3	64.8	66.3	67.8	69.3	70.8

※本公司享有變更規格之權益，恕不另行通知 ※Drawings and specifications are subject to change without prior notice.

M2

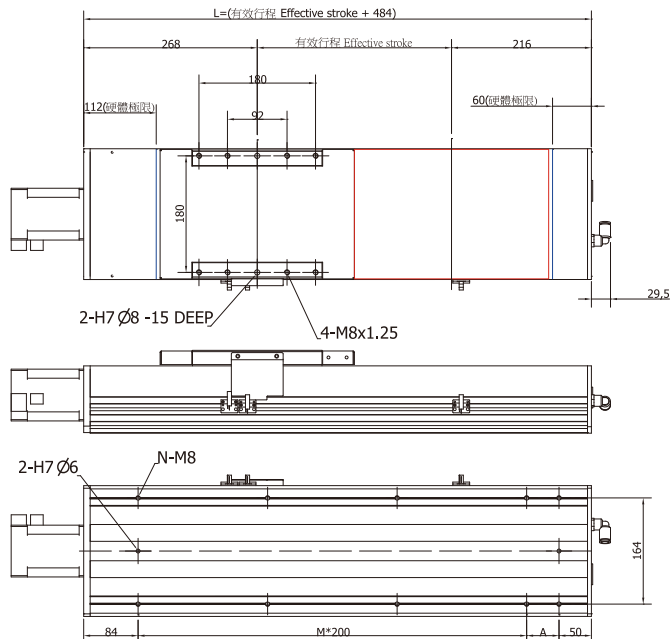
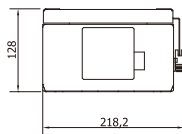

行程	100	150	200	250	300	350	400	450	500	550	600	650	700	750	800	850	900	950	1000	1050	1100	1150	1200	1250	1300	1350	1400	1450
L	584	634	684	734	784	834	884	934	984	1034	1084	1134	1184	1234	1284	1334	1384	1434	1484	1534	1584	1634	1684	1734	1784	1834	1884	1934
A	50	100	150	200	50	100	150	200	50	100	150	200	50	100	150	200	50	100	150	200	50	100	150	200	50	100	150	200
M	2	2	2	2	3	3	3	3	4	4	4	4	5	5	5	5	6	6	6	6	7	7	7	7	8	8	8	8
N	8	8	8	8	10	10	10	10	12	12	12	12	14	14	14	14	16	16	16	16	18	18	18	18	20	20	20	20
重量(kg)	28.3	29.8	31.3	32.8	34.3	35.8	37.3	38.8	40.3	41.8	43.3	44.8	46.3	47.8	49.3	50.8	52.3	53.8	55.3	56.8	58.3	59.8	61.3	62.8	64.3	65.8	67.3	68.8

※本公司享有變更規格之權益，恕不另行通知 ※Drawings and specifications are subject to change without prior notice.

M3

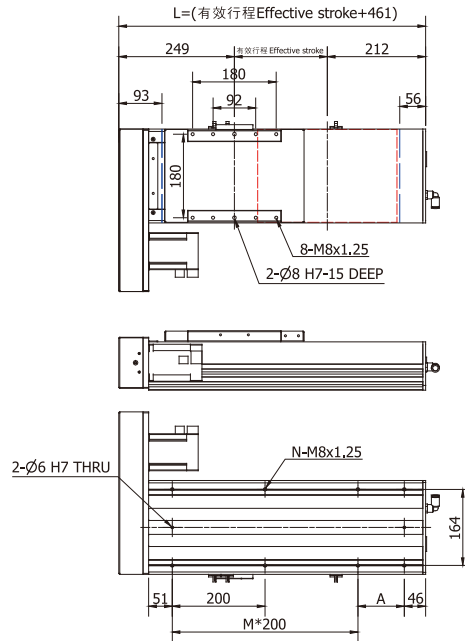
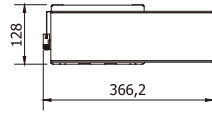

行程	100	150	200	250	300	350	400	450	500	550	600	650	700	750	800	850	900	950	1000	1050	1100	1150	1200	1250	1300	1350	1400	1450
L	561	611	661	711	761	811	861	911	961	1011	1061	1111	1161	1211	1261	1311	1361	1411	1461	1511	1561	1611	1661	1711	1761	1811	1861	1911
A	200	50	100	150	200	50	100	150	200	50	100	150	200	50	100	150	200	50	100	150	200	50	100	150	200	50	100	150
M	1	2	2	2	2	3	3	3	3	4	4	4	4	5	5	5	5	6	6	6	6	7	7	7	7	8	8	8
N	6	8	8	8	8	10	10	10	10	12	12	12	12	14	14	14	14	16	16	16	16	18	18	18	18	20	20	20
重量(kg)	28.1	29.6	31.1	32.6	34.1	35.6	37.1	38.6	40.1	41.6	43.1	44.6	46.1	47.6	49.1	50.6	52.1	53.6	55.1	56.6	58.1	59.6	61.1	62.6	64.1	65.6	67.1	68.6

※本公司享有變更規格之權益，恕不另行通知 ※Drawings and specifications are subject to change without prior notice.

M4

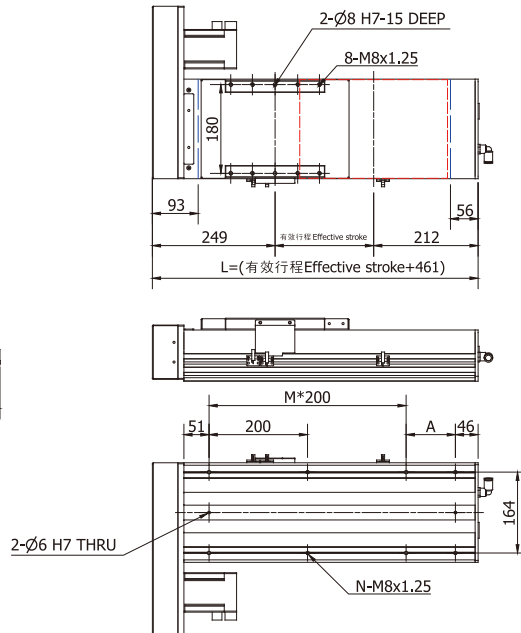
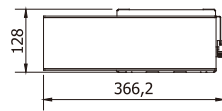

行程	100	150	200	250	300	350	400	450	500	550	600	650	700	750	800	850	900	950	1000	1050	1100	1150	1200	1250	1300	1350	1400	1450
L	561	611	661	711	761	811	861	911	961	1011	1061	1111	1161	1211	1261	1311	1361	1411	1461	1511	1561	1611	1661	1711	1761	1811	1861	1911
A	200	50	100	150	200	50	100	150	200	50	100	150	200	50	100	150	200	50	100	150	200	50	100	150	200	50	100	150
M	1	2	2	2	2	3	3	3	3	4	4	4	4	5	5	5	5	6	6	6	6	7	7	7	7	8	8	8
N	6	8	8	8	8	10	10	10	10	12	12	12	12	14	14	14	14	16	16	16	16	18	18	18	18	20	20	20
重量(kg)	28.1	29.6	31.1	32.6	34.1	35.6	37.1	38.6	40.1	41.6	43.1	44.6	46.1	47.6	49.1	50.6	52.1	53.6	55.1	56.6	58.1	59.6	61.1	62.6	64.1	65.6	67.1	68.6

※本公司享有變更規格之權益，恕不另行通知 ※Drawings and specifications are subject to change without prior notice.

M5

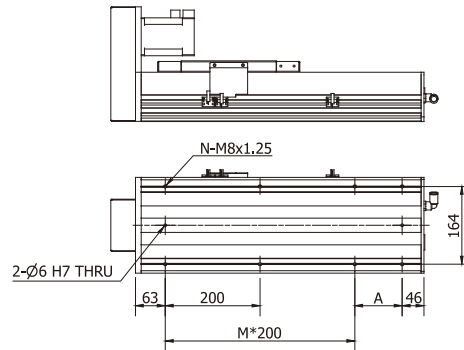
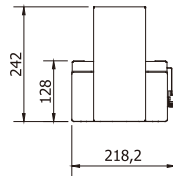
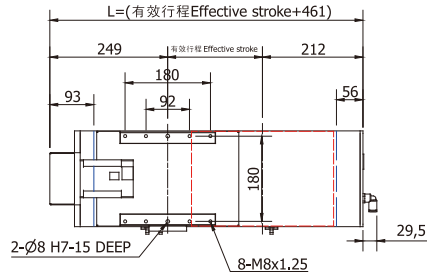

行程	100	150	200	250	300	350	400	450	500	550	600	650	700	750	800	850	900	950	1000	1050	1100	1150	1200	1250	1300	1350	1400	1450
L	561	611	661	711	761	811	861	911	961	1011	1061	1111	1161	1211	1261	1311	1361	1411	1461	1511	1561	1611	1661	1711	1761	1811	1861	1911
A	200	50	100	150	200	50	100	150	200	50	100	150	200	50	100	150	200	50	100	150	200	50	100	150	200	50	100	150
M	1	2	2	2	2	3	3	3	3	4	4	4	4	5	5	5	5	6	6	6	6	7	7	7	7	8	8	8
N	6	8	8	8	8	10	10	10	10	12	12	12	12	14	14	14	14	16	16	16	16	18	18	18	18	20	20	20
重量(kg)	28.1	29.6	31.1	32.6	34.1	35.6	37.1	38.6	40.1	41.6	43.1	44.6	46.1	47.6	49.1	50.6	52.1	53.6	55.1	56.6	58.1	59.6	61.1	62.6	64.1	65.6	67.1	68.6

※本公司享有變更規格之權益，恕不另行通知 ※Drawings and specifications are subject to change without prior notice.

M6

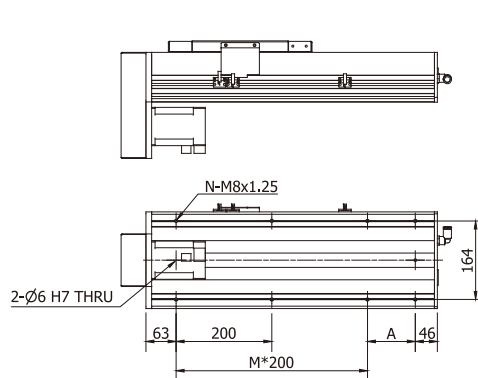
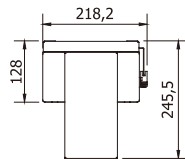
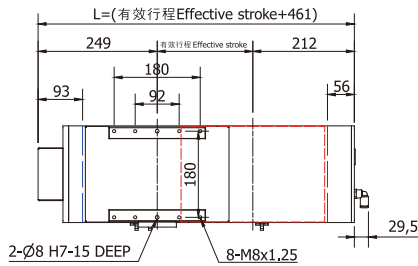

行程	100	150	200	250	300	350	400	450	500	550	600	650	700	750	800	850	900	950	1000	1050	1100	1150	1200	1250	1300	1350	1400	1450
L	561	611	661	711	761	811	861	911	961	1011	1061	1111	1161	1211	1261	1311	1361	1411	1461	1511	1561	1611	1661	1711	1761	1811	1861	1911
A	200	50	100	150	200	50	100	150	200	50	100	150	200	50	100	150	200	50	100	150	200	50	100	150	200	50	100	150
M	1	2	2	2	2	3	3	3	3	4	4	4	4	5	5	5	5	6	6	6	6	7	7	7	7	8	8	8
N	6	8	8	8	8	10	10	10	10	12	12	12	12	14	14	14	14	16	16	16	16	18	18	18	18	20	20	20
重量(kg)	28.1	29.6	31.1	32.6	34.1	35.6	37.1	38.6	40.1	41.6	43.1	44.6	46.1	47.6	49.1	50.6	52.1	53.6	55.1	56.6	58.1	59.6	61.1	62.6	64.1	65.6	67.1	68.6

※本公司享有變更規格之權益，恕不另行通知 ※Drawings and specifications are subject to change without prior notice.

C230D-YL10 - S2400 - M1 - M 750W - B

型號
Model

孔型與導程
Hole type and Lead

行程
Stroke

馬達方向
Motor direction

馬達廠牌及出力
Motor brand and output

煞車
Brake

Y 底部牙孔
Thread hole

- 馬達方向 Motor direction
- M1 馬達內置 Motor inside position
 - M2 馬達外置 Motor outside position
 - M3 馬達外置右側 Motor outside, rightward position
 - M4 馬達外置左側 Motor outside, leftward position
 - M5 馬達外置上方 Motor outside, upper position
 - M6 馬達外置下方 Motor outside, lower position

馬達廠牌及出力 Motor brand and output

- H 上銀 Hiwin
- X 西門子 Siemens
- M 三菱 Mitsubishi
- Y 安川 Yaskawa
- P 松下 Panasonic
- F 富士 Fuji
- T 台達 Delta

C230D規格表(C230D Specification):

馬達出力 AC Servo motor output(W)	750W						
重複定位精度 Repeatability(mm)	±0.01						
滾珠螺桿外徑 B.S(Ø)	25	25	32	25	32	40	
滾珠螺桿導程 Lead(mm)	5	10	20	25	32	40	
最快速度 Maximum speed(mm/sec)	250	500	1000	1250	1600	2000	
最大載重 Maximum payload(kg)	水平使用 (H)	125	105	90	80	70	60
	垂直使用 (V)	58	48	28	24	21	17
額定推力 Rated thrust(N)	2050	1025	560	420	350	270	
行程 Stroke(mm)	100~2400 50 間隔 (interval)						

靜態容許負載慣量
Static Loading Moment

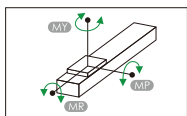

(單位:N.m) (Unit:N.m)

水平使用時 Static Loading Moment

MY	2025
MP	2025
MR	1810

線性滑軌23x22-2支

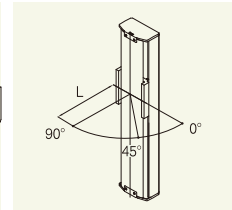
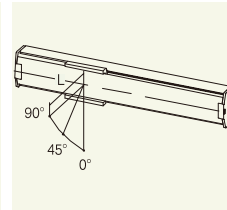
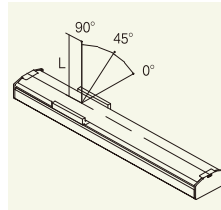

水平安裝應用(單位:mm)
Horizontal use

導程 Payload	0°	45°	90°	
Lead 40	40kg	482	603	1008
	50kg	223	393	835
	60kg	189	244	525
Lead 32	50kg	482	603	1008
	60kg	223	393	835
	70kg	189	244	525
Lead 20	55kg	765	922	1449
	75kg	454	571	1216
	90kg	305	393	935
Lead 10	65kg	603	770	1493
	85kg	400	511	1236
	105kg	188	243	1019
Lead 5	90kg	408	539	1366
	105kg	227	291	1078
	125kg	83	100	904

牆面安裝應用(單位:mm)
Wall installation use

導程 Payload	0°	45°	90°	
Lead 40	40kg	700	354	412
	50kg	543	235	325
	60kg	399	141	235
Lead 32	50kg	700	354	412
	60kg	543	235	325
	70kg	399	141	235
Lead 20	55kg	1305	601	588
	75kg	1002	427	397
	90kg	731	298	265
Lead 10	65kg	1095	531	502
	85kg	737	430	378
	105kg	581	237	195
Lead 5	90kg	987	421	387
	105kg	645	303	216
	125kg	412	157	89

垂直安裝應用(單位:mm)
During vertical use

導程 Payload	0°	45°	90°	
Lead 40	7kg	1175	802	1175
	12kg	893	560	893
	17kg	531	278	531
Lead 32	11kg	1175	802	1175
	16kg	893	560	893
	21kg	531	278	531
Lead 20	18kg	1270	903	1270
	23kg	876	678	876
	28kg	753	468	753
Lead 10	23kg	1810	1238	1810
	33kg	1152	791	1152
	48kg	713	564	713
Lead 5	33kg	979	631	979
	43kg	669	370	669
	58kg	222	48	222

*滑塊表面中心到搬送物重心的距離(僅供參考)

Distance center of slider top to center of gravity of object being transported (For reference only)

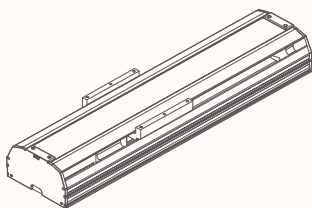

M1

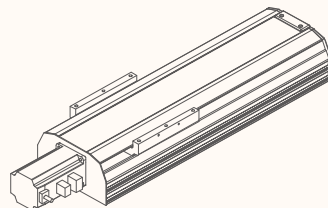

M2

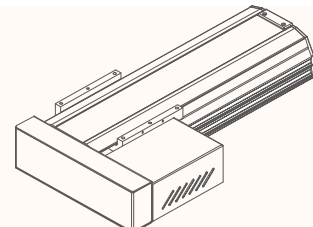

M3

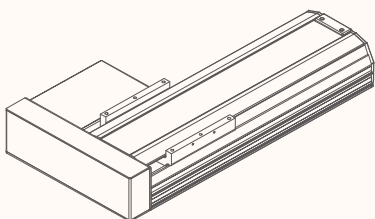

M4

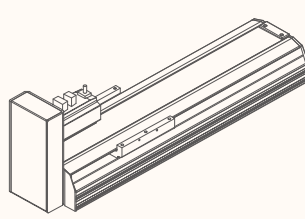

M5

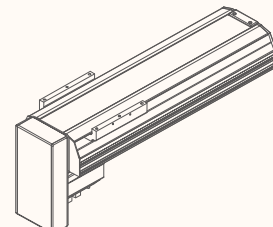

M6

M1

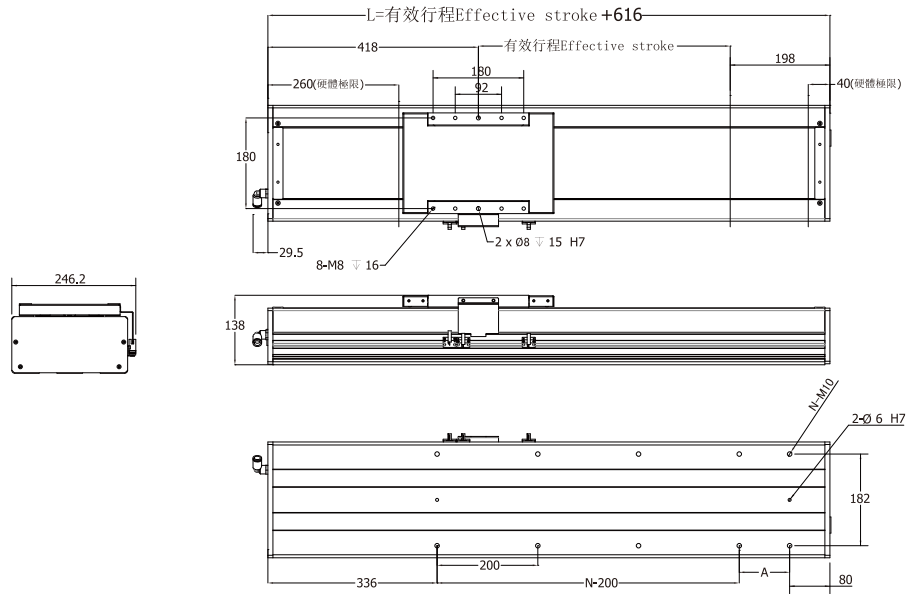

有效行程	50	100	150	200	250	300	350	400	450	500	550	600	650	700	750	800	850	900	950	1000	1050	1100	1150	1200
L	656	706	756	806	856	906	956	1006	1056	1106	1156	1206	1256	1306	1356	1406	1456	1506	1556	1606	1656	1706	1756	1806
A	50	100	150	200	50	100	150	200	50	100	150	200	50	100	150	200	50	100	150	200	50	100	150	200
M	2	2	3	3	4	4	5	5	6	6	7	7	8	8	9	9	10	10	11	11	12	12	13	13
N	6	6	8	8	10	10	12	12	14	14	16	16	18	18	20	20	22	22	24	24	26	26	28	28
重量 (kg)	31.3	32.8	34.3	35.8	37.3	38.8	40.3	41.8	43.3	44.8	46.3	47.8	49.3	50.8	52.3	53.8	55.3	56.8	58.3	59.8	61.3	62.8	64.3	65.8

有效行程	1250	1300	1350	1400	1450	1500	1550	1600	1650	1700	1750	1800	1850	1900	1950	2000	2050	2100	2150	2200	2250	2300	2350	2400
L	1856	1906	1956	2006	2056	2106	2156	2206	2256	2306	2356	2406	2456	2506	2556	2606	2656	2706	2756	2806	2856	2906	2956	3006
A	50	100	150	200	50	100	150	200	50	100	150	200	50	100	150	200	50	100	150	200	50	100	150	200
M	14	14	15	15	16	16	17	17	18	18	19	19	20	20	21	21	22	22	23	23	24	24	25	25
N	32	32	32	32	34	34	36	36	38	38	40	40	42	42	44	44	46	46	48	48	50	50	52	52
重量 (kg)	67.3	68.8	70.3	71.8	73.3	74.8	76.3	77.8	79.3	80.8	82.3	83.8	85.3	86.8	88.3	89.8	91.3	92.8	94.3	95.8	97.3	98.8	100	102

※本公司享有變更規格之權益，恕不另行通知 ※Drawings and specifications are subject to change without prior notice.

M2

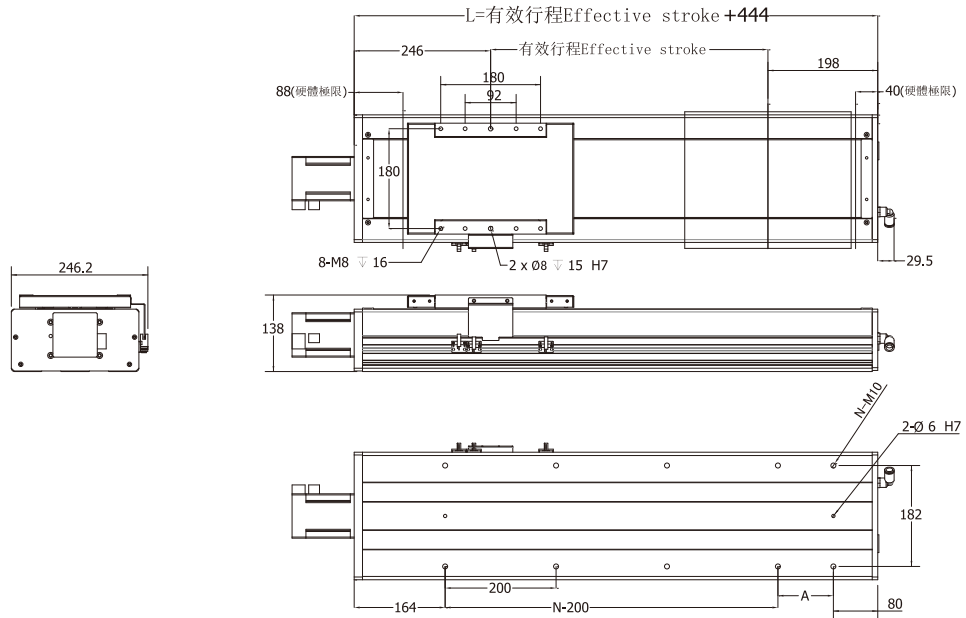

有效行程	50	100	150	200	250	300	350	400	450	500	550	600	650	700	750	800	850	900	950	1000	1050	1100	1150	1200
L	494	544	594	644	694	744	794	844	894	944	994	1044	1094	1144	1194	1244	1294	1344	1394	1444	1494	1544	1594	1644
A	150	200	50	150	200	50	150	200	50	100	150	200	50	100	150	200	50	100	150	200	50	100	150	200
M	2	2	3	3	4	4	5	5	6	6	7	7	8	8	9	9	10	10	11	11	12	12	13	13
N	6	6	8	8	10	10	12	12	14	14	16	16	18	18	20	20	22	22	24	24	26	26	28	28
重量 (kg)	29.3	30.8	32.3	33.8	35.3	36.8	38.3	39.8	41.3	42.8	44.3	45.8	47.3	48.8	50.3	51.8	53.3	54.8	56.3	57.8	59.3	60.8	62.3	63.8

有效行程	1250	1300	1350	1400	1450	1500	1550	1600	1650	1700	1750	1800	1850	1900	1950	2000	2050	2100	2150	2200	2250	2300	2350	2400
L	1694	1744	1794	1844	1894	1944	1994	2044	2094	2144	2194	2244	2294	2344	2394	2444	2494	2544	2594	2644	2694	2744	2794	2844
A	50	100	150	200	50	100	150	200	50	100	150	200	50	100	150	200	50	100	150	200	50	100	150	200
M	14	14	15	15	16	16	17	17	18	18	19	19	20	20	21	21	22	22	23	23	24	24	25	25
N	32	32	32	32	34	34	36	36	38	38	40	40	42	42	44	44	46	46	48	48	50	50	52	52
重量 (kg)	65.3	66.8	68.3	69.8	71.3	72.8	74.3	75.8	77.3	78.8	80.3	81.8	83.3	84.8	86.3	87.8	89.3	90.8	92.3	93.8	95.3	96.8	98.3	99.8

※本公司享有變更規格之權益，恕不另行通知 ※Drawings and specifications are subject to change without prior notice.

M3

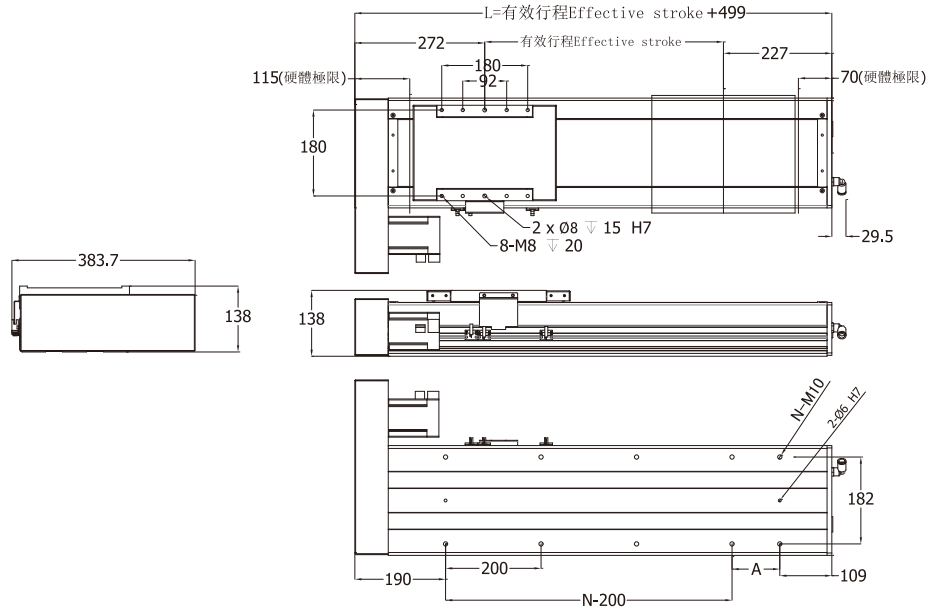

有效行程	50	100	150	200	250	300	350	400	450	500	550	600	650	700	750	800	850	900	950	1000	1050	1100	1150	1200
L	549	599	649	699	749	799	849	899	949	999	1049	1099	1149	1199	1249	1299	1349	1399	1449	1499	1549	1599	1649	1699
A	50	100	150	200	50	100	150	200	50	100	150	200	50	100	150	200	50	100	150	200	50	100	150	200
M	2	2	3	3	4	4	5	5	6	6	7	7	8	8	9	9	10	10	11	11	12	12	13	13
N	6	6	8	8	10	10	12	12	14	14	16	16	18	18	20	20	22	22	24	24	26	26	28	28
重量 (kg)	29.1	30.6	32.1	33.6	35.1	36.6	38.1	39.6	41.1	42.6	44.1	45.6	47.1	48.6	50.1	51.6	53.1	54.6	56.1	57.6	59.1	60.6	62.1	63.6

有效行程	1250	1300	1350	1400	1450	1500	1550	1600	1650	1700	1750	1800	1850	1900	1950	2000	2050	2100	2150	2200	2250	2300	2350	2400
L	1749	1799	1849	1899	1949	1999	2049	2099	2149	2199	2249	2299	2349	2399	2449	2499	2549	2599	2649	2699	2749	2799	2849	2899
A	50	100	150	200	50	100	150	200	50	100	150	200	50	100	150	200	50	100	150	200	50	100	150	200
M	14	14	15	15	16	16	17	17	18	18	19	19	20	20	21	21	22	22	23	23	24	24	25	25
N	32	32	32	32	34	34	36	36	38	38	40	40	42	42	44	44	46	46	48	48	50	50	52	52
重量 (kg)	65.1	66.6	68.1	69.6	71.1	72.6	74.1	75.6	77.1	78.6	80.1	81.6	83.1	84.6	86.1	87.6	89.1	90.6	92.1	93.6	95.1	96.6	98.1	99.6

※本公司享有變更規格之權益，恕不另行通知 ※Drawings and specifications are subject to change without prior notice.

M4

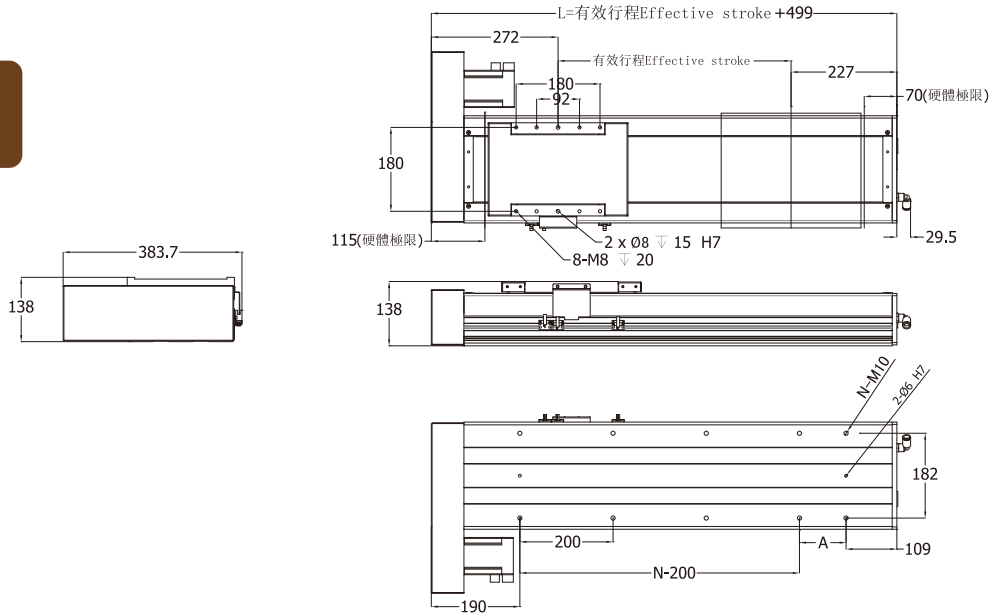

有效行程	50	100	150	200	250	300	350	400	450	500	550	600	650	700	750	800	850	900	950	1000	1050	1100	1150	1200
L	549	599	649	699	749	799	849	899	949	999	1049	1099	1149	1199	1249	1299	1349	1399	1449	1499	1549	1599	1649	1699
A	50	100	150	200	50	100	150	200	50	100	150	200	50	100	150	200	50	100	150	200	50	100	150	200
M	2	2	3	3	4	4	5	5	6	6	7	7	8	8	9	9	10	10	11	11	12	12	13	13
N	6	6	8	8	10	10	12	12	14	14	16	16	18	18	20	20	22	22	24	24	26	26	28	28
重量 (kg)	29.1	30.6	32.1	33.6	35.1	36.6	38.1	39.6	41.1	42.6	44.1	45.6	47.1	48.6	50.1	51.6	53.1	54.6	56.1	57.6	59.1	60.6	62.1	63.6

有效行程	1250	1300	1350	1400	1450	1500	1550	1600	1650	1700	1750	1800	1850	1900	1950	2000	2050	2100	2150	2200	2250	2300	2350	2400
L	1749	1799	1849	1899	1949	1999	2049	2099	2149	2199	2249	2299	2349	2399	2449	2499	2549	2599	2649	2699	2749	2799	2849	2899
A	50	100	150	200	50	100	150	200	50	100	150	200	50	100	150	200	50	100	150	200	50	100	150	200
M	14	14	15	15	16	16	17	17	18	18	19	19	20	20	21	21	22	22	23	23	24	24	25	25
N	32	32	32	32	34	34	36	36	38	38	40	40	42	42	44	44	46	46	48	48	50	50	52	52
重量 (kg)	65.1	66.6	68.1	69.6	71.1	72.6	74.1	75.6	77.1	78.6	80.1	81.6	83.1	84.6	86.1	87.6	89.1	90.6	92.1	93.6	95.1	96.6	98.1	99.6

※本公司享有變更規格之權益，恕不另行通知 ※Drawings and specifications are subject to change without prior notice.

M5

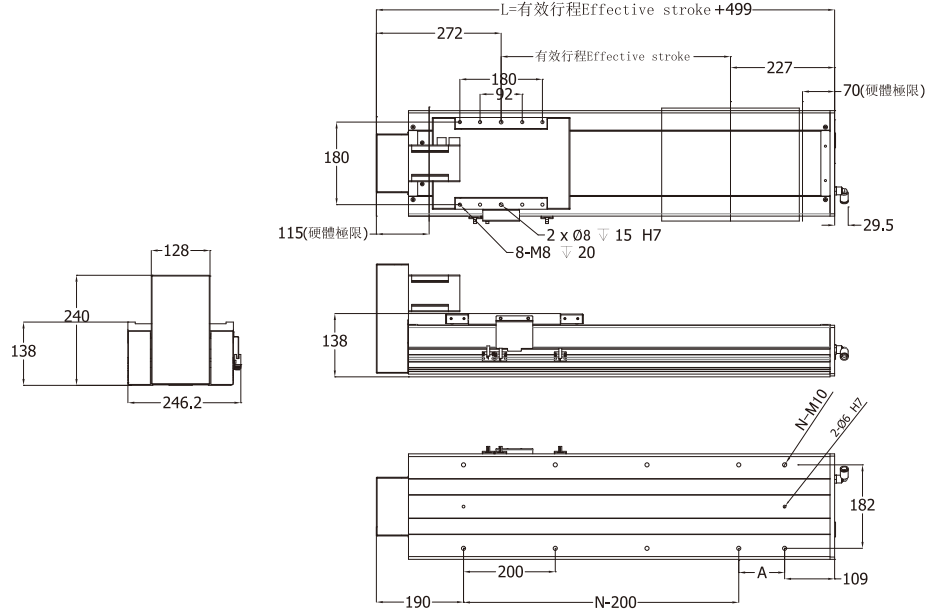

有效行程	50	100	150	200	250	300	350	400	450	500	550	600	650	700	750	800	850	900	950	1000	1050	1100	1150	1200
L	549	599	649	699	749	799	849	899	949	999	1049	1099	1149	1199	1249	1299	1349	1399	1449	1499	1549	1599	1649	1699
A	50	100	150	200	50	100	150	200	50	100	150	200	50	100	150	200	50	100	150	200	50	100	150	200
M	2	2	3	3	4	4	5	5	6	6	7	7	8	8	9	9	10	10	11	11	12	12	13	13
N	6	6	8	8	10	10	12	12	14	14	16	16	18	18	20	20	22	22	24	24	26	26	28	28
重量 (kg)	29.1	30.6	32.1	33.6	35.1	36.6	38.1	39.6	41.1	42.6	44.1	45.6	47.1	48.6	50.1	51.6	53.1	54.6	56.1	57.6	59.1	60.6	62.1	63.6

有效行程	1250	1300	1350	1400	1450	1500	1550	1600	1650	1700	1750	1800	1850	1900	1950	2000	2050	2100	2150	2200	2250	2300	2350	2400
L	1749	1799	1849	1899	1949	1999	2049	2099	2149	2199	2249	2299	2349	2399	2449	2499	2549	2599	2649	2699	2749	2799	2849	2899
A	50	100	150	200	50	100	150	200	50	100	150	200	50	100	150	200	50	100	150	200	50	100	150	200
M	14	14	15	15	16	16	17	17	18	18	19	19	20	20	21	21	22	22	23	23	24	24	25	25
N	32	32	32	32	34	34	36	36	38	38	40	40	42	42	44	44	46	46	48	48	50	50	52	52
重量 (kg)	65.1	66.6	68.1	69.6	71.1	72.6	74.1	75.6	77.1	78.6	80.1	81.6	83.1	84.6	86.1	87.6	89.1	90.6	92.1	93.6	95.1	96.6	98.1	99.6

※本公司享有變更規格之權益，恕不另行通知 ※Drawings and specifications are subject to change without prior notice.

M6

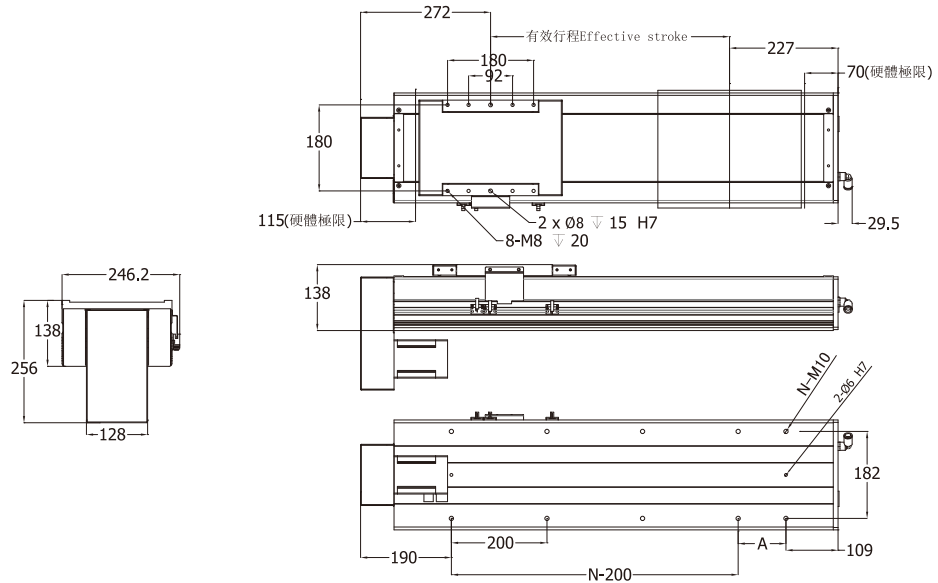

有效行程	50	100	150	200	250	300	350	400	450	500	550	600	650	700	750	800	850	900	950	1000	1050	1100	1150	1200
L	549	599	649	699	749	799	849	899	949	999	1049	1099	1149	1199	1249	1299	1349	1399	1449	1499	1549	1599	1649	1699
A	50	100	150	200	50	100	150	200	50	100	150	200	50	100	150	200	50	100	150	200	50	100	150	200
M	2	2	3	3	4	4	5	5	6	6	7	7	8	8	9	9	10	10	11	11	12	12	13	13
N	6	6	8	8	10	10	12	12	14	14	16	16	18	18	20	20	22	22	24	24	26	26	28	28
重量 (kg)	29.1	30.6	32.1	33.6	35.1	36.6	38.1	39.6	41.1	42.6	44.1	45.6	47.1	48.6	50.1	51.6	53.1	54.6	56.1	57.6	59.1	60.6	62.1	63.6

有效行程	1250	1300	1350	1400	1450	1500	1550	1600	1650	1700	1750	1800	1850	1900	1950	2000	2050	2100	2150	2200	2250	2300	2350	2400
L	1749	1799	1849	1899	1949	1999	2049	2099	2149	2199	2249	2299	2349	2399	2449	2499	2549	2599	2649	2699	2749	2799	2849	2899
A	50	100	150	200	50	100	150	200	50	100	150	200	50	100	150	200	50	100	150	200	50	100	150	200
M	14	14	15	15	16	16	17	17	18	18	19	19	20	20	21	21	22	22	23	23	24	24	25	25
N	32	32	32	32	34	34	36	36	38	38	40	40	42	42	44	44	46	46	48	48	50	50	52	52
重量 (kg)	65.1	66.6	68.1	69.6	71.1	72.6	74.1	75.6	77.1	78.6	80.1	81.6	83.1	84.6	86.1	87.6	89.1	90.6	92.1	93.6	95.1	96.6	98.1	99.6

※本公司享有變更規格之權益，恕不另行通知 ※Drawings and specifications are subject to change without prior notice.